

830 Laser Alignment Tool

Quick Reference Guide



To prevent possible electrical shock, fire, or personal injury, read the "830 Safety Sheet" before you use this Product.

Go to www.fluke.com to register your product, download manuals, and find more information.

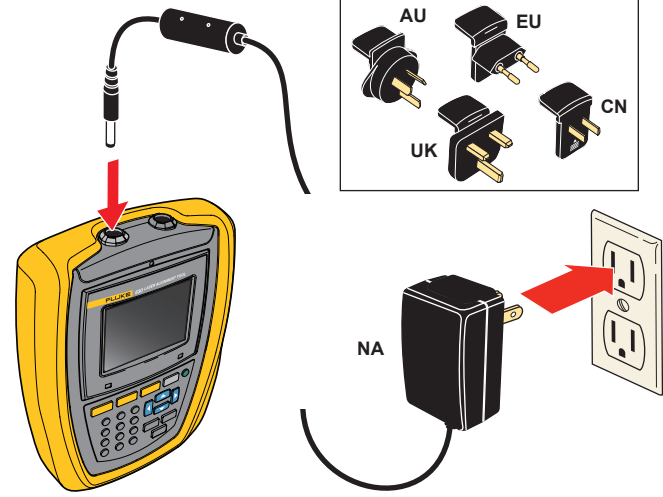

Preparation

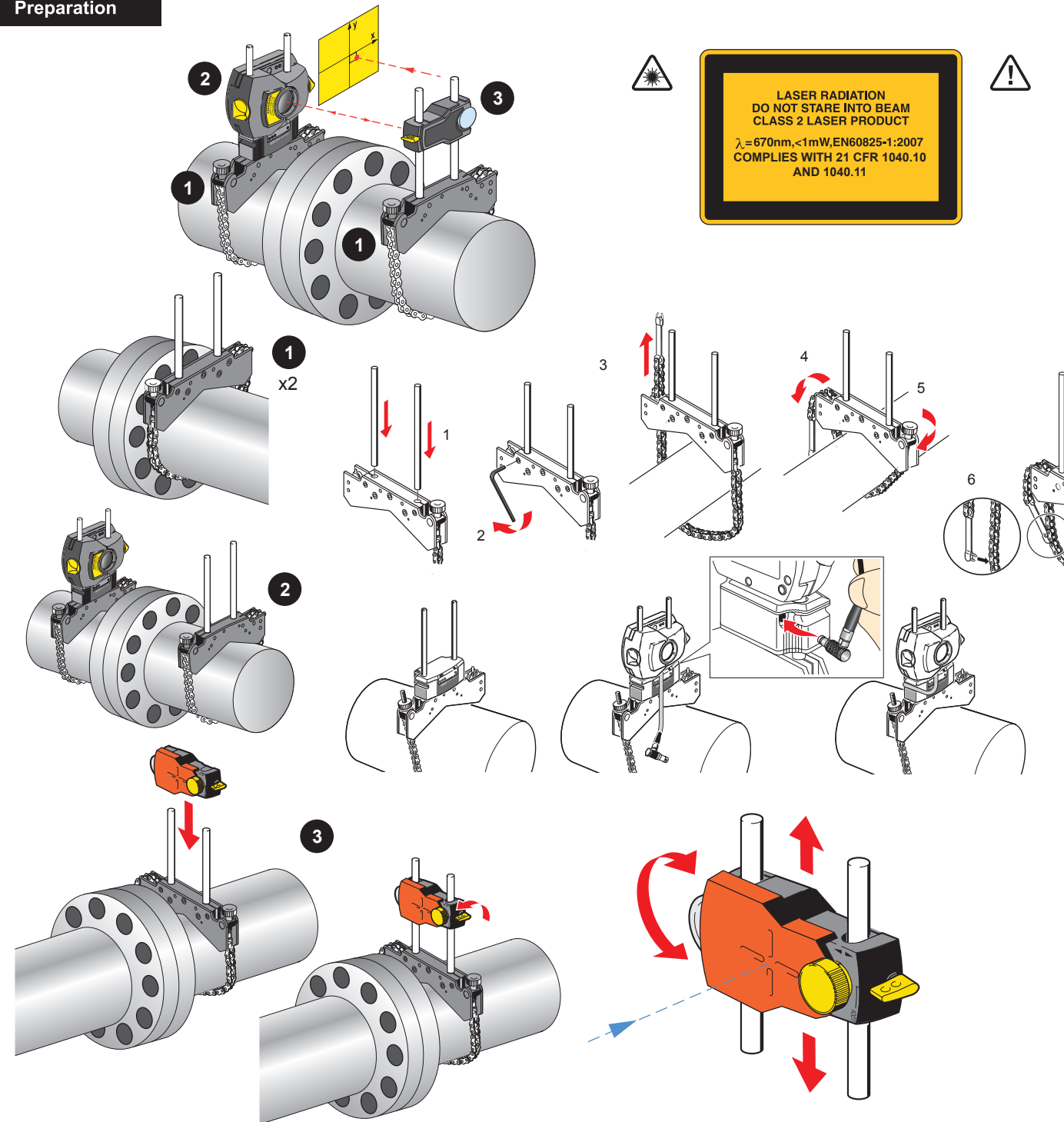

Step 1 Setup: Enter Machine Dimensions

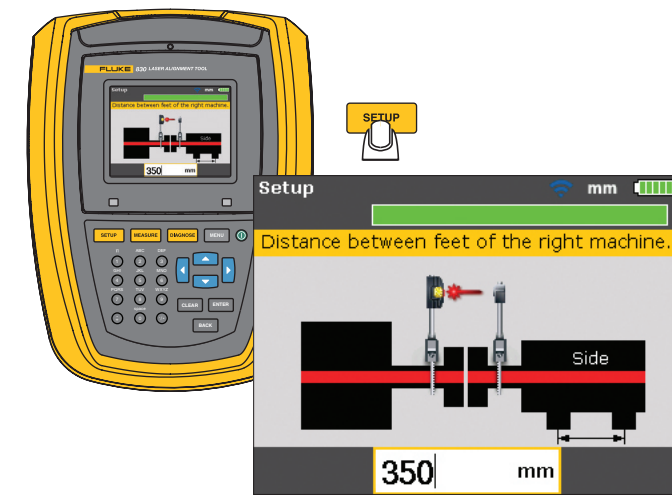

1 Take dimensions

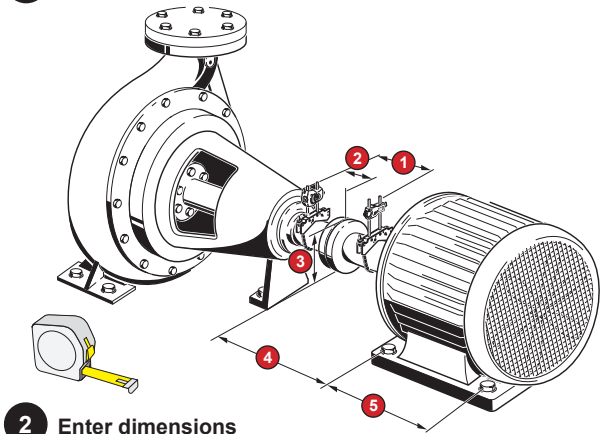

2 Enter dimensions

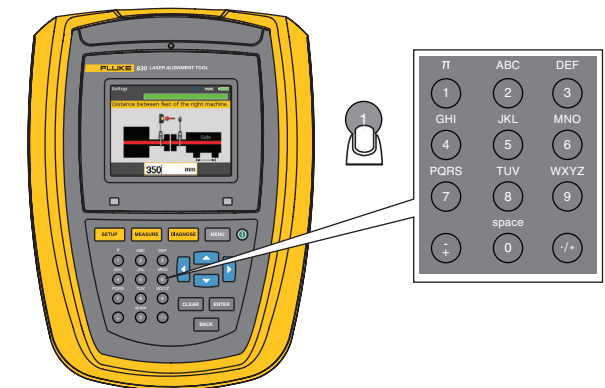

Overview of 830



Step 2 Measure: Take 3 Readings

1 **MEASURE** OR **MENU**

Menu mm

Measurement Options

- Compass Mode
- Clock Mode
- Averaging
- Extend
- Sensor Selection

3 **Take 1st measurement when green**

Measure - COMPASS MODE mm

Press ENTER to start measurement.

Laser READY

WID: 59500050

0 points

5 **Take 2nd measurement when green**

Measure - COMPASS MODE mm

Press ENTER to take a point.

Laser READY

WID: 59500050

1 points

2 **Adjust prism**

4 **Rotate shaft**

6 **Rotate shaft and take 3rd measurement when green**

Measure - COMPASS MODE mm

Press ENTER to take a point.

Laser READY

WID: 59500010

2 points

Step 3 Diagnose: Make Foot Correction

1 **Diagnose**

Vertical	Horizontal
Gap -0.04	Gap +0.22
Offset -0.05	Offset +0.08

Alignment condition

Tolerance	Tolerance Bar	LED Color
Excellent Tolerance		Green
Acceptable Tolerance		Yellow
Out-of-Tolerance		Orange
Grossly Misaligned		Red

Adjustment needed

2A

2B

Alignment values

A

B

C

D

2A

2B

Final Check

1 **Move**

1 **Move** mm

Angle ok, please wait or press ENTER to continue.

Move sensor to a green position.

310° Angle in range

2 **Move**

2 **Move** mm

Press ENTER to select move direction.

Laser READY

Choose Move orientation

Horizontal Vertical

3 **Move - Horizontal**

3 **Move - Horizontal** mm

Move in progress, press ENTER to stop.

Laser READY

4 **Move - Horizontal**

4 **Move - Horizontal** mm

Press ENTER to choose an option.

Laser READY

Move Options

Stop and Measure Re-enter Move Extend

5 **Menu**

5 **Menu** mm

Main menu

- Left Machine
- Coupling Tol.
- Right Machine
- Move
- Soft Foot
- File
- Measure Options
- Print Report
- Config
- Turn Off

Optional Check: Soft Foot

1 **Menu**

1 **Menu** mm

Main menu

- Left Machine
- Coupling Tol.
- Right Machine
- Move
- Soft Foot
- File
- Measure Options
- Print Report
- Config
- Turn Off

2 **Soft Foot**

2 **Soft Foot** mm

Press ENTER to measure indicated foot.

Laser READY

3 **Soft Foot**

3 **Soft Foot** mm

Loosen the bolt and press Enter to take soft foot reading.

Laser READY

4 **Soft Foot**

4 **Soft Foot** mm

Press ENTER to measure indicated foot.

Laser READY

5 **Soft Foot**

5 **Soft Foot** mm

Press ENTER to display soft foot tolerances.

Soft foot has been detected.

Laser READY