



# N 186.3 AP.9 | SP.9 | SP.13 E | ST.9 | ST.13 E

## PERFORMANCE DATA

Series model	Flow rate at atm. pressure (l/min)	Max. operating pressure (bar rel./psig)	Ultimate vacuum (mbar abs.)
N 186.3 AP.9 E	23.0 ± 10 %	0.5/7.3	15
N 186.3 SP.9 E	23.0 ± 10 %	0.5/7.3	15
N 186.3 SP.13 E	23.0 ± 10 %	0.5/7.3	15
N 186.3 ST.9 E	21.0 ± 10 %	0.5/7.3	25
N 186.3 ST.13 E	21.0 ± 10 %	0.5/7.3	25

Flow rate determined at 20 °C, 1013 mbar abs.  
(Pressure 0 to 1013 mbar abs. in accordance with ISO 21360-1/2)

## N 186.3 \_\_.9 E | S.13 E

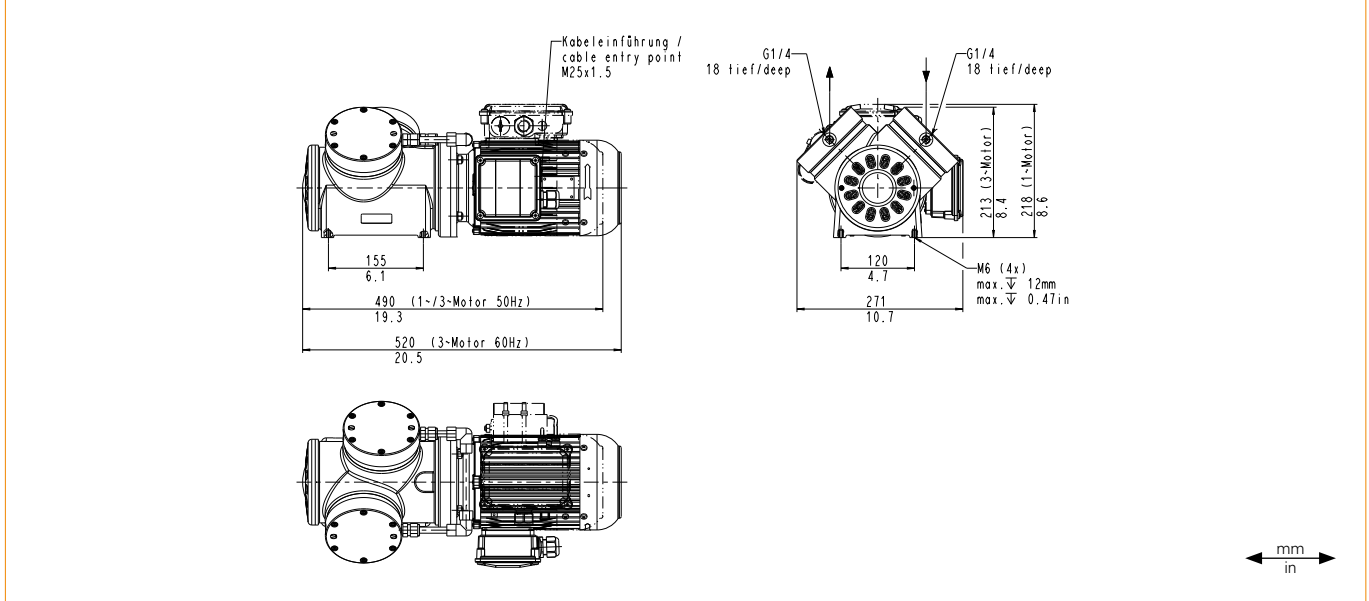

## N 186.3 P. E

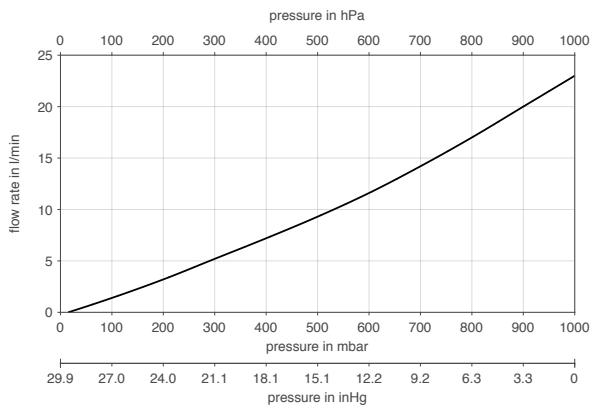

Flow rate determined at 20 °C, 1013 mbar abs.  
(Pressure 0 to 1013 mbar abs. in accordance with ISO 21360-1/2)

## N 186.3 T. E

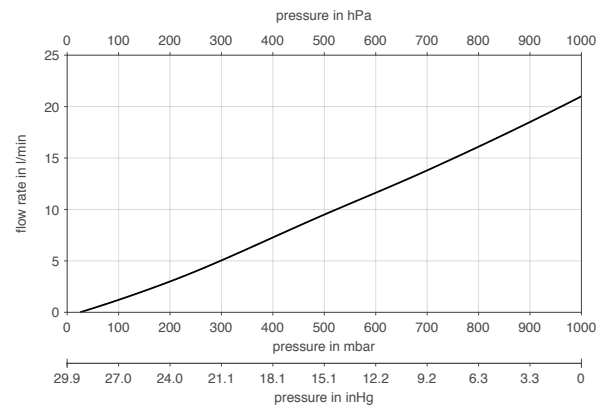

Flow rate determined at 20 °C, 1013 mbar abs.  
(Pressure 0 to 1013 mbar abs. in accordance with ISO 21360-1/2)

## N 186.3 | PUMP DOWN TIME FOR 20 LITER VESSEL

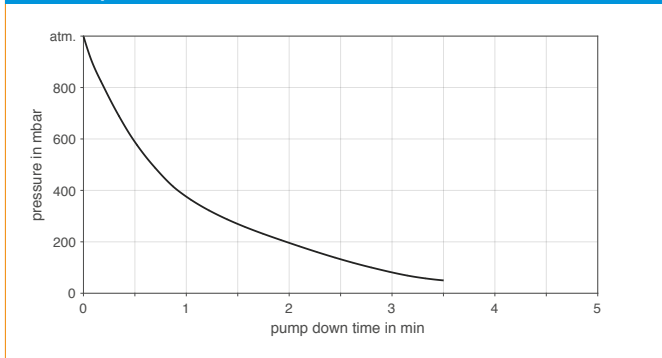

# N 186.3 SP.12 E

## PERFORMANCE DATA

Series model	Flow rate at atm. pressure (l/min)	Max. operating pressure (bar rel./psig)	Ultimate vacuum (mbar abs.)
N 186.3 SP.12 E	23.0 ± 10 %	0.5/7.3	15

Flow rate determined at 20 °C, 1013 mbar abs.  
 (Pressure 0 to 1013 mbar abs. in accordance with ISO 21360-1/2)

## N 186.3 SP.12 E

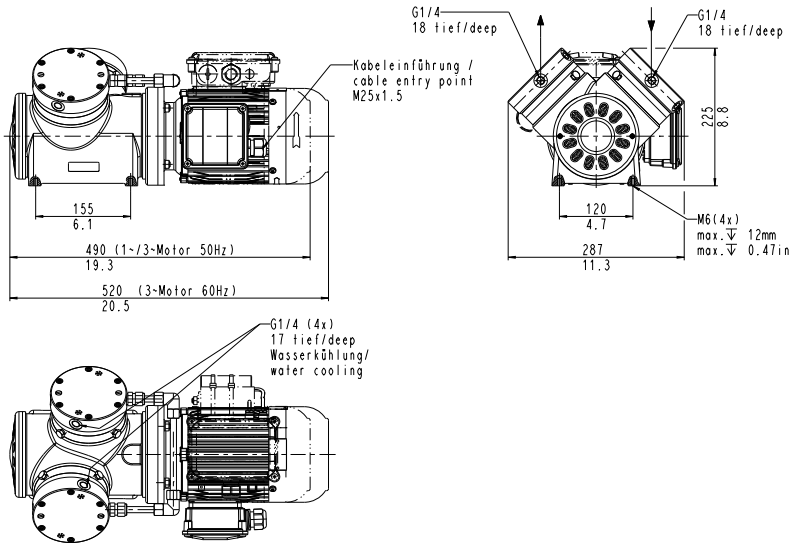

## N 186.3 SP.12 E

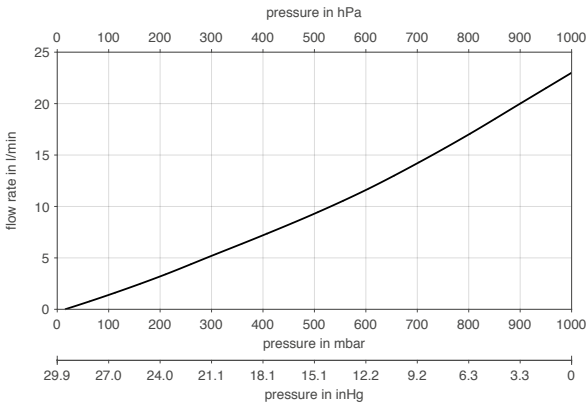

Flow rate determined at 20 °C, 1013 mbar abs.  
 (Pressure 0 to 1013 mbar abs. in accordance with ISO 21360-1/2)

## N 186.3 | PUMP DOWN TIME FOR 20 LITER VESSEL

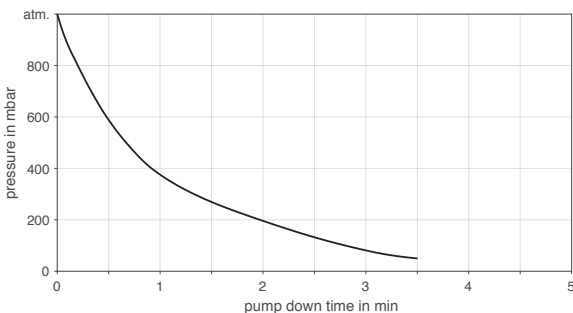

## ACCESSORIES

Description	Part No.
Base plate with rubber-bonded metals	310102
Connection water cooling device S_9   S_13	303901
Connection water cooling device SP.12	303902
Wrench for retainer plate	018816
O-ring for lock screw	026056
Inlet filter G 1/4	316661

## SPARE PARTS

Description	Part No.
Spare parts kit N 186.3 _P.9 E	315460
Spare parts kit N 186.3 SP.13 E	315461
Spare parts kit N 186.3 ST.9 E	307823
Spare parts kit N 186.3 ST.13 E	315463
Spare parts kit N 186.3 SP.12 E	315462

The performance values for the series models shown on this data sheet were determined under test conditions. The actual performance values may differ and depend in particular on the usage conditions and therefore on the specific application, on the parameters of the components involved in the user's system and on any technical modifications carried out which deviate from the standard configuration or the as delivered condition.

If individual designs have been created for specific customers on the basis of series models, other technical performance data may apply.

Before operation begins, the relevant operating instructions and/or assembly or installation instructions should be read and the safety information contained in these instructions should be noted.

KNF reserves the right to make changes to the product and the associated documentation without prior notice to the customer.



[www.knf.com](http://www.knf.com)

# YOUR LOCAL PARTNER AROUND THE WORLD

## KNF SALES ORGANIZATION

**Australia** KNF Regional Office  
Moreland West VIC 3055  
Tel. +61 3 9386 4959  
info@knf.com.au  
www.knf.com.au

**Benelux Netherlands** KNF Verder B.V.  
3451 GG Vleuten  
Tel. +31 30 677 92 40  
info@knf-verder.nl  
www.knf-verder.nl

**Benelux Belgium and Luxemburg**  
KNF Verder N.V.  
2630 Aartselaar  
Tel. +32 3 871 96 24  
info@knf.be  
www.knf.be

**China** KNF Technology (Shanghai) Co., Ltd.  
Shanghai 201203  
Tel. +86 21 5109 9695  
info@knf.com.cn  
www.knf.com.cn

**France** KNF Neuberger SAS  
68128 Village-Neuf  
Tel. +33 389 70 35 00  
info@knf.fr  
www.knf.fr

**Germany** KNF Neuberger GmbH  
79112 Freiburg  
Tel. +49 7664 5909 0  
info@knf.de  
www.knf.de

**India** KNF Pumps + Systems (India) Pvt. Ltd.  
Hinjewadi Pune 411 057  
Tel. +91 20 640 13 923  
info@knfpumps.in  
www.knfpumps.in

**Italy** KNF Italia S.r.l.  
20063 Cernusco s. Naviglio (MI)  
Tel. +39 02 929 04 91  
info@knf.it  
www.knf.it

**Japan** KNF Japan Co. Ltd.  
Tokyo 104-0033  
Tel. +81 3 3551 7931  
info@knf.co.jp  
www.knf.co.jp

**Korea** KNF Neuberger Ltd.  
135-502 Seoul  
Tel. +82 2 959 0255  
knf@knfkorea.com  
www.knfkorea.com

**Latin America** KNF Regional Office  
Tel. +1 609 649 1010  
gb@knf.com  
www.knf.com/es

**Morocco, Tunisia, Algeria**  
KNF Neuberger SAS  
68128 Village-Neuf  
Tel. +33 389 70 35 00  
info@knf.fr  
www.knf.fr

**Singapore** KNF Regional Office  
Tel. +65 9722 1994  
info@knf.com.sg  
www.knf.com.sg

**Sweden, Finland, Denmark, Norway**  
KNF Neuberger AB  
117 43 Stockholm  
Tel. +46 8 744 51 13  
info@knf.se  
www.knf.se

**Switzerland** KNF Neuberger AG  
8362 Balzerswil  
Tel. +41 71 973 99 30  
knf@knf.ch  
www.knf.ch

**UK, Ireland** KNF Neuberger U.K., Ltd.  
Witney, Oxfordshire OX28 4FA  
Tel. +44 1993 77 83 73  
info@knf.co.uk  
www.knf.co.uk

**USA, Canada** KNF Neuberger, Inc.  
Trenton, NJ 08691-1810  
Tel. +1 609 890 8600  
knfusa@knf.com  
www.knfusa.com

## KNF PRODUCT CENTERS

**Gas Pumps** KNF Neuberger GmbH  
DE-79112 Freiburg  
info@knf.de  
www.knf.de

**Micro Gas Pumps** KNF Micro AG  
CH-6260 Reiden  
info@knf-micro.ch  
www.knf-micro.ch

**Liquid Pumps** KNF Flodos AG  
CH-6210 Sursee  
info@knf-flodos.ch  
www.knf-flodos.ch