

N 922 SERIES – 50 HZ VERSION EXPLOSION PROOF PUMPS



N 922 FTE Ex

ADVANTAGES

- High chemical resistance
- Robust design
- Easy to service – wearing parts are inexpensively and easy to replace
- Maintenance work can be easily carried out even on assembled analytical systems
- Durable even with difficult operating conditions
- Motor approved in accordance with ATEX/IECEx

POSSIBLE AREAS OF USE

- Environmental monitoring – especially in potentially explosive fields
- Process industry
- Chemical industry

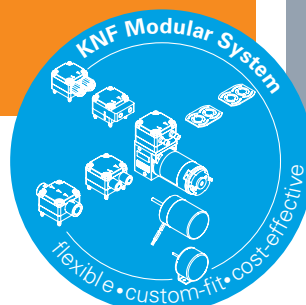

Please visit our website
www.knf.com
to get more information

PERFORMANCE DATA				
Series model	N 922 8L		N 922 16L	
Material design	FTE Ex	FT.29 E Ex	FTE Ex	FT.29 E Ex
Pump head	Modified PTFE			
Diaphragm	PTFE-coated			
Valves	FFPM			
Flow rate at atm. pressure (l/min)	7.5 ± 10 %	3.0–7.5 ± 10 %	16.0 ± 10 %	10.0–16.0 ± 10 %
Ultimate vacuum (mbar abs.)	350		200	
Max. operating pressure (bar rel./psig)	1.5/21.8		1.0/14.5	
Permissible ambient temperature (°C)	+5 ... +50			
Permissible media temperature (°C)	+5 ... +50			
Weight (kg/lbs)	7.2/15.8			
ELECTRICAL DATA				
Voltage (V)	230			
Motor	Capacitor motor			
Protection class motor	IP 66			
Protection class pump	IP 54			
Frequency (Hz)	50			
Power P ₂ (W)	120			
I _N (A)	1.09			
Explosion protection pump parts	Ex II 2G Ex h IIB+H2 T3 Gb			
Explosion protection capacitor motor	Ex II 2G Ex de IIC T4			

N 922 FTE EX 8L – 50 HZ VERSION

PERFORMANCE DATA

Series model	Flow rate at atm. pressure (l/min) ¹⁾	Max. operating pressure (bar rel./psig)	Ultimate vacuum (mbar abs.)
N 922 FTE Ex 8L	7.5 ± 10 %	1.5/21.8	350

¹⁾ Flow rate determined at 20 °C, 1013 mbar abs.
(Pressure 0 to 1013 mbar abs. in accordance with ISO 21360-1/2)

N 922 FTE EX 8L

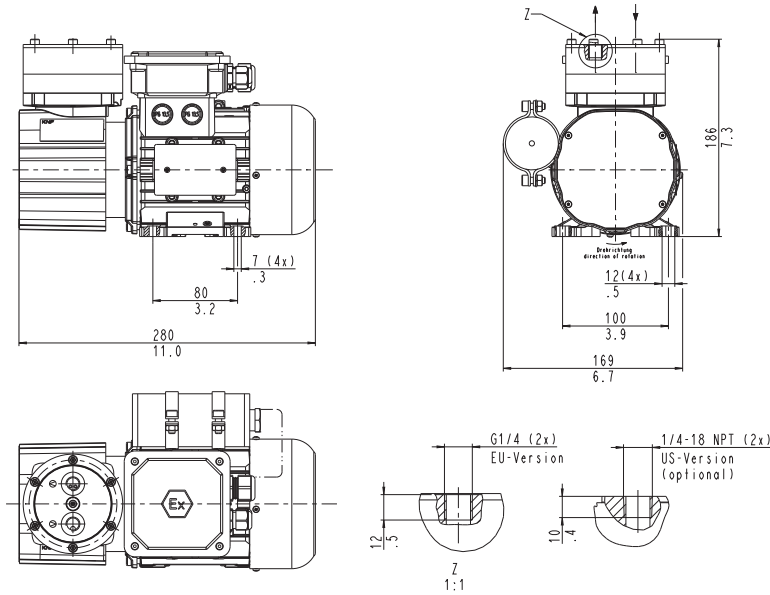

* EU-Version: G1/4 (2x)
US-Version: 1/4-18 NPT (2x)
** EU-Version: Ø 22, 0.5 tief/deep (2x)
US-Version: nicht vorhanden/non-existent

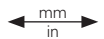

N 922 FTE EX 8L

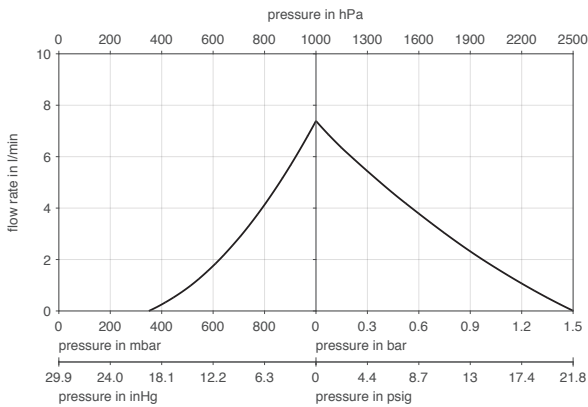

Flow rate determined at 20 °C, 1013 mbar abs.
(Pressure 0 to 1013 mbar abs. in accordance with ISO 21360-1/2)

N 922 FTE EX 8L | PUMP UP TIME FOR 20 LITER VESSEL

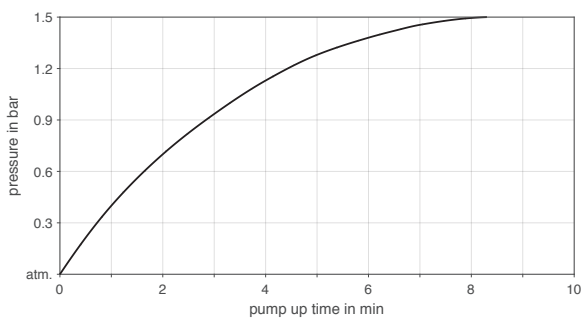

N 922 FTE EX 8L | PUMP DOWN TIME FOR 20 LITER VESSEL

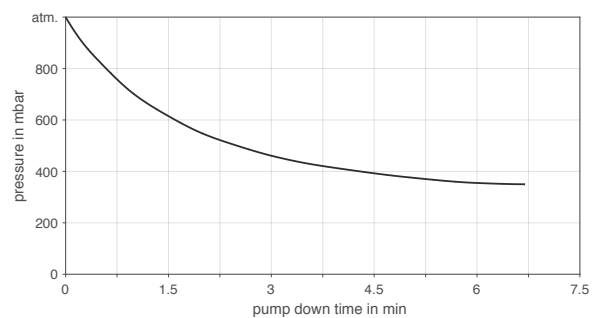

N 922 FT.29 E EX 8L – 50 HZ VERSION

PERFORMANCE DATA

Series model	Flow rate at atm. pressure (l/min) ¹⁾	Max. operating pressure (bar rel./psig)	Ultimate vacuum (mbar abs.)
N 922 FT.29 E Ex 8L	3.0–7.5 ± 10 %	1.5/21.8	350

¹⁾ Flow rate determined at 20 °C, 1013 mbar abs.
(Pressure 0 to 1013 mbar abs. in accordance with ISO 21360-1/2)

N 922 FT.29 E EX 8L

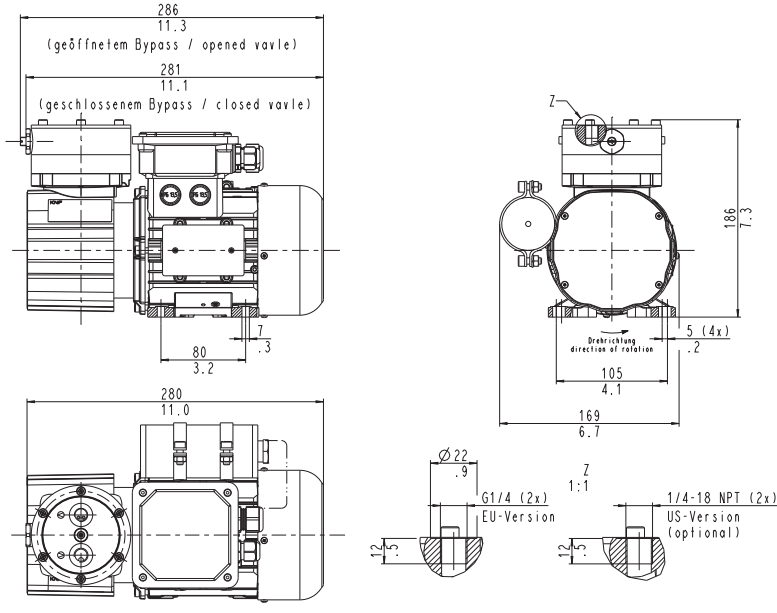

* EU-Version: G1/4 (2x)
US-Version: 1/4-18 NPT (2x)
** EU-Version: Ø 22, 0.5 tief/deep (2x)
US-Version: nicht vorhanden/non-existent

N 922 FT.29 E EX 8L

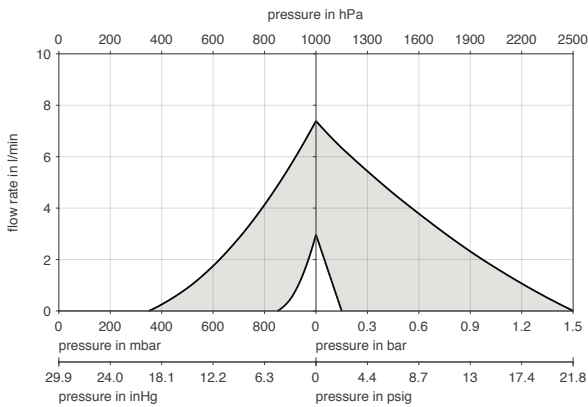

Flow rate determined at 20 °C, 1013 mbar abs.
(Pressure 0 to 1013 mbar abs. in accordance with ISO 21360-1/2)

N 922 FT.29 E EX 8L | PUMP UP TIME FOR 20 LITER VESSEL

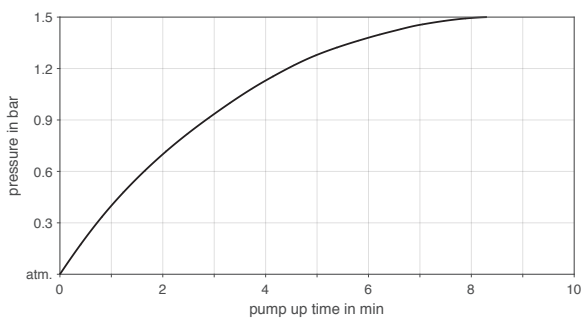

N 922 FT.29 E EX 8L | PUMP DOWN TIME FOR 20 LITER VESSEL

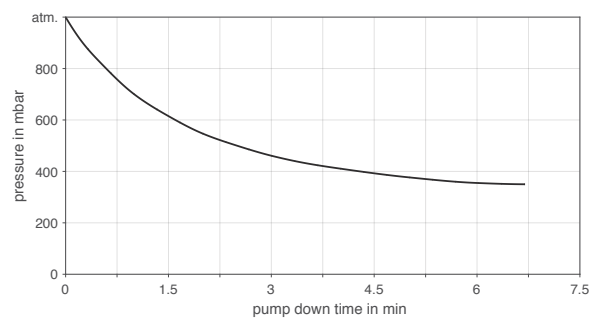

N 922 FTE EX 16L – 50 HZ VERSION

PERFORMANCE DATA

Series model	Flow rate at atm. pressure (l/min) ¹⁾	Max. operating pressure (bar rel./psig)	Ultimate vacuum (mbar abs.)
N 922 FTE Ex 16L	16.0 ± 10 %	1.0/14.5	200

¹⁾ Flow rate determined at 20 °C, 1013 mbar abs.
(Pressure 0 to 1013 mbar abs. in accordance with ISO 21360-1/2)

N 922 FTE EX 16L

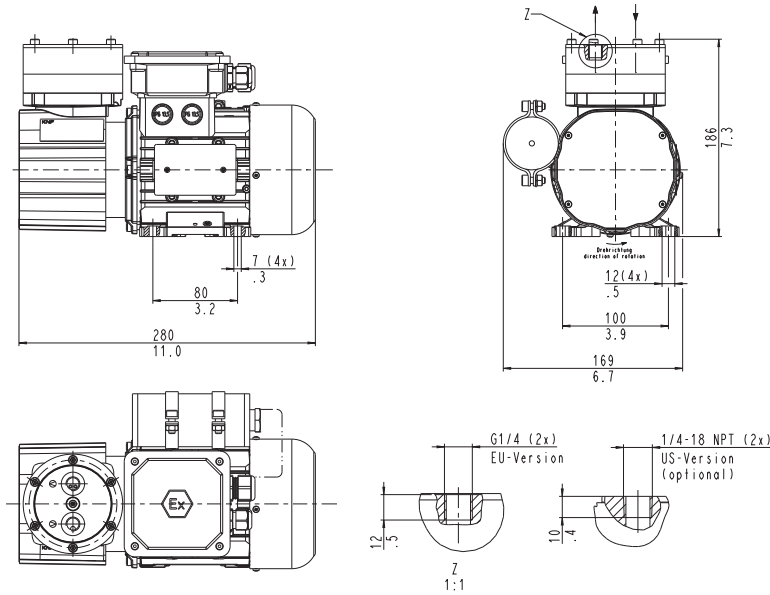

* EU-Version: G1/4 (2x)
US-Version: 1/4-18 NPT (2x)
** EU-Version: Ø 22, 0.5 tief/deep (2x)
US-Version: nicht vorhanden/non-existent

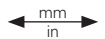

N 922 FTE EX 16L

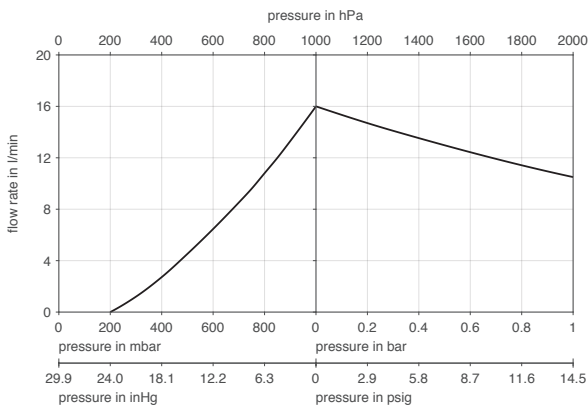

Flow rate determined at 20 °C, 1013 mbar abs.
(Pressure 0 to 1013 mbar abs. in accordance with ISO 21360-1/2)

N 922 FTE EX 16L | PUMP UP TIME FOR 20 LITER VESSEL

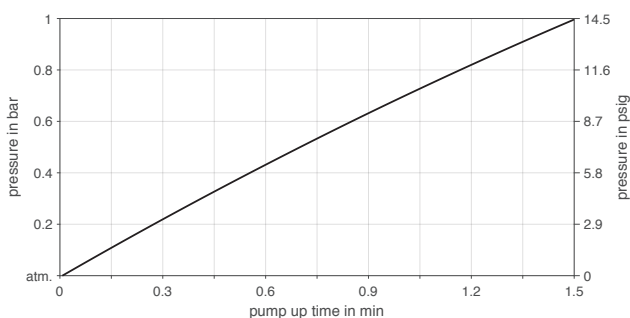

N 922 FTE EX 16L | PUMP DOWN TIME FOR 20 LITER VESSEL

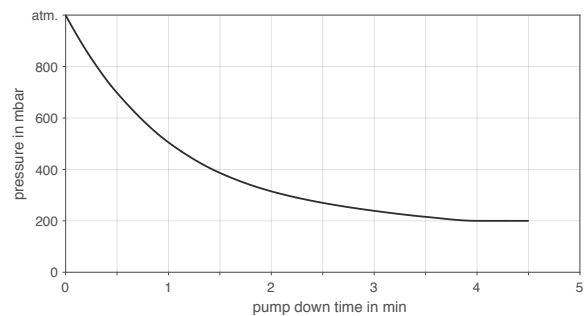

N 922 FT.29 E EX 16L – 50 HZ VERSION

PERFORMANCE DATA

Series model	Flow rate at atm. pressure (l/min) ¹⁾	Max. operating pressure (bar rel./psig)	Ultimate vacuum (mbar abs.)
N 922 FT.29 E Ex 16L	10.0–16.0 ± 10 %	1.0/14.5	200

¹⁾ Flow rate determined at 20 °C, 1013 mbar abs.
(Pressure 0 to 1013 mbar abs. in accordance with ISO 21360-1/2)

N 922 FT.29 E EX 16L

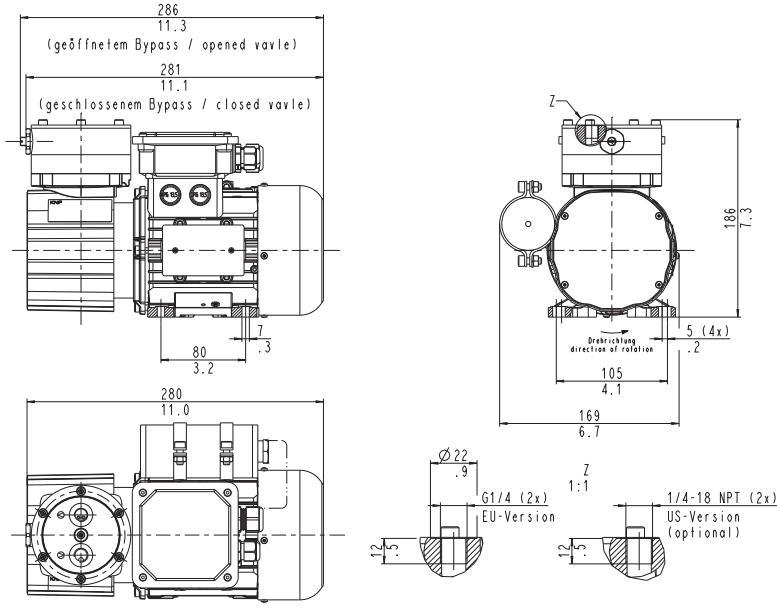

* EU-Version: G1/4 (2x)
US-Version: 1/4-18 NPT (2x)
** EU-Version: Ø 22, 0.5 tief/deep (2x)
US-Version: nicht vorhanden/non-existent

N 922 FT.29 E EX 16L

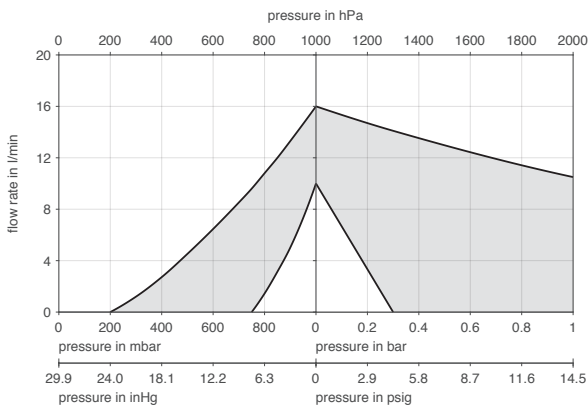



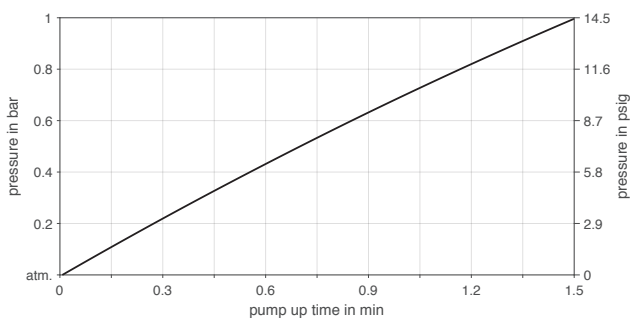

Flow rate determined at 20 °C, 1013 mbar abs.
(Pressure 0 to 1013 mbar abs. in accordance with ISO 21360-1/2)

N 922 FT.29 E EX 16L | PUMP UP TIME FOR 20 LITER VESSEL

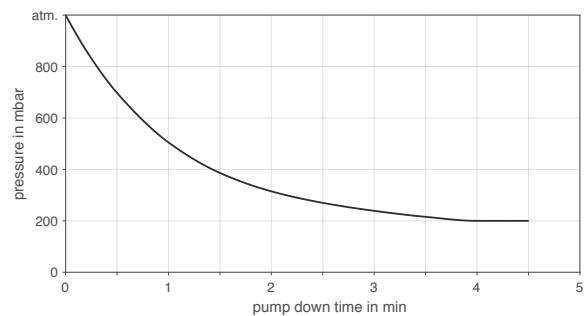

N 922 FT.29 E EX 16L | PUMP DOWN TIME FOR 20 LITER VESSEL

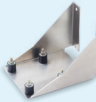

ACCESSORIES		
Description	Illustration	Part No.
Tube fitting for tube ID 6, PVDF		303623
Mounting kit shock mounts and mounting bracket		313181
Mounting kit shock mounts		313180

SPARE PARTS	
Description	Part No.
Spare parts kit N 922 FTE Ex	313515
Spare parts kit N 922 FT.29 E Ex	313516
Throttle valve (only for .29 versions)	309629

The performance values for the series models shown on this data sheet were determined under test conditions. The actual performance values may differ and depend in particular on the usage conditions and therefore on the specific application, on the parameters of the components involved in the user's system and on any technical modifications carried out which deviate from the standard configuration or the as delivered condition.

If individual designs have been created for specific customers on the basis of series models, other technical performance data may apply. Before operation begins, the relevant operating instructions and/or assembly or installation instructions should be read and the safety information contained in these instructions should be noted. KNF reserves the right to make changes to the product and the associated documentation without prior notice to the customer.



www.knf.com

YOUR LOCAL PARTNER AROUND THE WORLD

KNF SALES ORGANIZATION

Australia KNF Regional Office
Moreland West VIC 3055
Tel. +61 3 9386 4959
info@knf.com.au
www.knf.com.au

Benelux Netherlands KNF Verder B.V.
3451 GG Vleuten
Tel. +31 30 677 92 40
info@knf-verder.nl
www.knf-verder.nl

Benelux Belgium and Luxemburg
KNF Verder N.V.
2630 Aartselaar
Tel. +32 3 871 96 24
info@knf.be
www.knf.be

China KNF Technology (Shanghai) Co., Ltd.
Shanghai 201203
Tel. +86 21 5109 9695
info@knf.com.cn
www.knf.com.cn

France KNF Neuberger SAS
68128 Village-Neuf
Tel. +33 389 70 35 00
info@knf.fr
www.knf.fr

Germany KNF Neuberger GmbH
79112 Freiburg
Tel. +49 7664 5909 0
info@knf.de
www.knf.de

India KNF Pumps + Systems (India) Pvt. Ltd.
Hinjewadi Pune 411 057
Tel. +91 20 640 13 923
info@knfpumps.in
www.knfpumps.in

Italy KNF Italia S.r.l.
20063 Cernusco s. Naviglio (MI)
Tel. +39 02 929 04 91
info@knf.it
www.knf.it

Japan KNF Japan Co. Ltd.
Tokyo 104-0033
Tel. +81 3 3551 7931
info@knf.co.jp
www.knf.co.jp

Korea KNF Neuberger Ltd.
135-502 Seoul
Tel. +82 2 959 0255
knf@knfkorea.com
www.knfkorea.com

Latin America KNF Regional Office
Tel. +1 609 649 1010
gb@knf.com
www.knf.com/es

Morocco, Tunisia, Algeria
KNF Neuberger SAS
68128 Village-Neuf
Tel. +33 389 70 35 00
info@knf.fr
www.knf.fr

Singapore KNF Regional Office
Tel. +65 9722 1994
info@knf.com.sg
www.knf.com.sg

Sweden, Finland, Denmark, Norway
KNF Neuberger AB
117 43 Stockholm
Tel. +46 8 744 51 13
info@knf.se
www.knf.se

Switzerland KNF Neuberger AG
8362 Balzerswil
Tel. +41 71 973 99 30
knf@knf.ch
www.knf.ch

UK, Ireland KNF Neuberger U.K., Ltd.
Witney, Oxfordshire OX28 4FA
Tel. +44 1993 77 83 73
info@knf.co.uk
www.knf.co.uk

USA, Canada KNF Neuberger, Inc.
Trenton, NJ 08691-1810
Tel. +1 609 890 8600
knfusa@knf.com
www.knfusa.com

KNF PRODUCT CENTERS

Gas Pumps KNF Neuberger GmbH
DE-79112 Freiburg
info@knf.de
www.knf.de

Micro Gas Pumps KNF Micro AG
CH-6260 Reiden
info@knf-micro.ch
www.knf-micro.ch

Liquid Pumps KNF Flodos AG
CH-6210 Sursee
info@knf-flodos.ch
www.knf-flodos.ch