

Contents

1 Purpose	2
2 Specifications	2
3 Delivery set	4
4 Design and principle of operation.....	4
5 Safety measures.....	9
6 Preparation for operation	10
7 Operation order.....	11
8 Technical maintenance	12
9 Storage.....	13
10 Possible troubles and their elimination.....	14
11 Warranty	14
12 Data on claims	14
13 Acceptance certificate.....	14
14 Packing certificate	15
15 Note.....	15
16 Appendix 1	16

1 Purpose

1.1 Automated hydraulic calibrating system (GSKA or system) is a system consisting of: electro-hydraulic control cabinet, power unit, in the form of electrified rod (plunger) pump, joystick unit. GSKA is intended to control operation elastic element pressure gauges and other measuring instruments (MI), as well as to create pressure in closed cavities of hydraulic devices in automated mode without waste of physical efforts, by pressing slightly the joystick handle.

1.2 Reference measuring instruments (RMI) are not included in standard GSKA supply.

1.3 GSKA is not a MI, that's why it is not subject to primary and periodic verification. It is required to select RMI on the basis of verification procedures of MI under verification.

1.4 GSKA is intended to operate in laboratory conditions at ambient air temperature from 10 to 30°C at relative humidity of 80% maximum.

2 Specifications

Generated pressure

upper limit 60 (600) MPa (kgf/cm²)

lower limit 0 (0)¹ MPa (kgf/cm²)

Bowl capacity 500 ml

Supply voltage 220 V ±10%

Supply frequency..... 50 Hz

Consumed power, maximum..... 400 W

Weight

power unit²..... 55 kg

control cabinet² 16 kg

joystick² 1.5 kg

Overall dimensions (L×W×H), maximum

power unit..... 1050×253×256 mm

control cabinet..... 483×267×200 mm

joystick..... 190×120×100 mm

collector..... 760×130×208 mm

Total number of the collector connections 2, 3 or 4 pcs

¹ It is not recommended to use GSKA with measuring instruments with upper measurement limit less than 1 MPa.

²Not considering connection cables and pipes

Process liquid oil³, water⁴

3 Delivery set

Power unit.....	1
Control cabinet.....	1
Joystick unit.....	1
Collector for 2, 3 or 4 connections.....	<i>Is ordered separately</i>
Connection nuts (set).....	1
Nut handle (set).....	1
Data cable.....	2
Power cable.....	1
Pressure release needle.....	1
Bowl cover.....	1
Operation manual, certificate.....	1
Plastic pipe 10×8 mm.....	1
Pipe of stainless steel, 6×1.5 mm.....	2
SPA (set).....	1

Design and principle on the next page →

³Transformer oil GOST 982-80, GOST10121-76.

⁴Distilled water GOST 6709-72.

4 Design and principle of operation

4.1 The external view of the system is given in fig. 1.

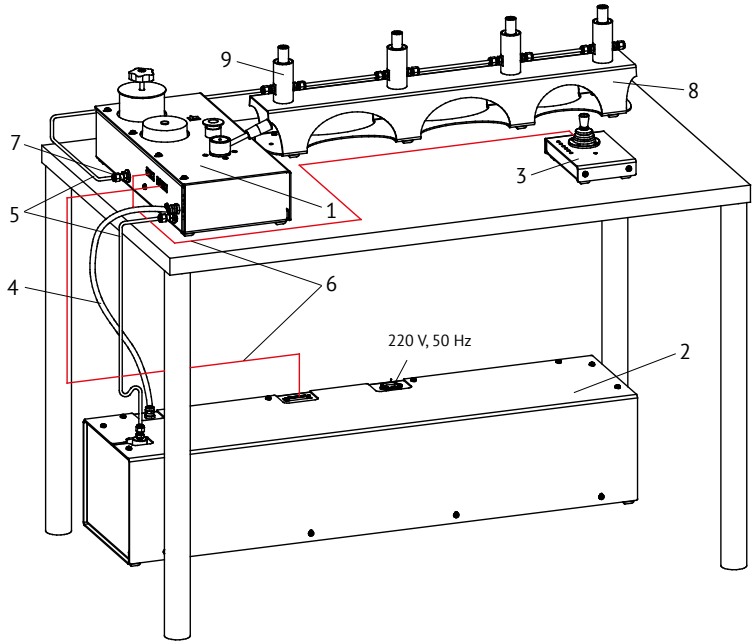

Fig. 1. External view of the system:

- 1 – control cabinet; 2 – power unit; 3 – joystick;
- 4 – low pressure pipeline; 5 – high pressure pipeline;
- 6 – data cables (are shown conventionally);
- 7 – output fitting of the system; 8 – collector; 9 – rack

4.2 The external view of the control cabinet is given in fig. 2.

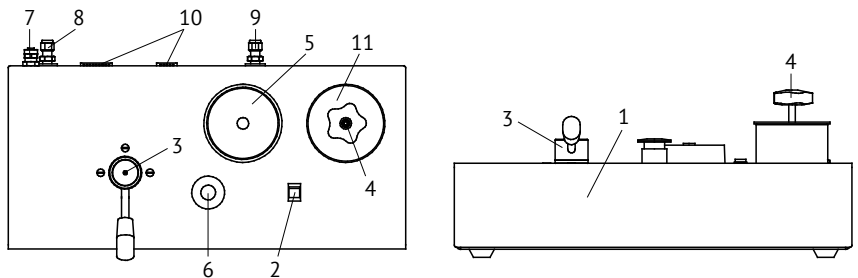

Fig. 2. External view of the control cabinet:

- 1 – body; 2 – system start button; 3 – mode selection lever;
- 4 – pressure release valve; 5 – protection manometer; 6 – emergency stop

- button; 7 – low pressure pipeline fitting;
- 8 – high pressure pipeline fitting; 9 – output fitting;
- 10 – plugs connecting data cables; 11 – bowl

4.3 The external view of the power unit is given in fig. 3.

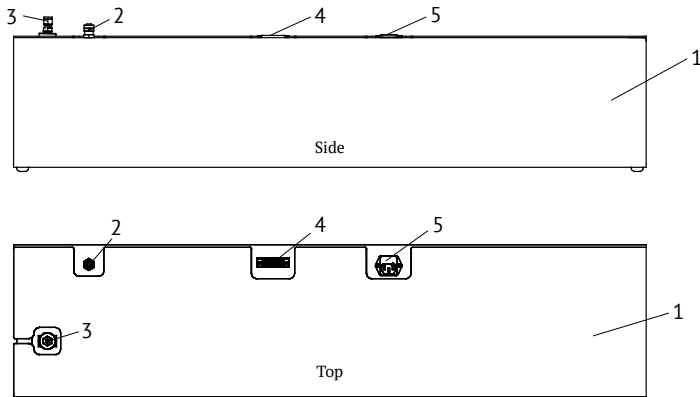

Fig. 3. External view of the power unit:

- 1 – body; 2 – low pressure pipeline fitting;
- 3 – high pressure pipeline fitting; 4 – interface cable plug;
- 5 – main connection plug 220 V, 50 Hz

4.4 The external view of the joystick unit is given in fig. 4.

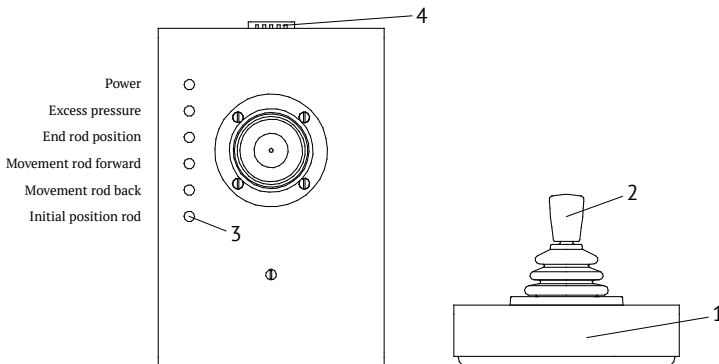

Fig. 4. External view of the joystick:

- 1 – body; 2 – joystick handle; 3 – system-status indicators;
- 4 – interface cable plug

4.5 The external view of the collector for 3 MI is given in fig. 5.

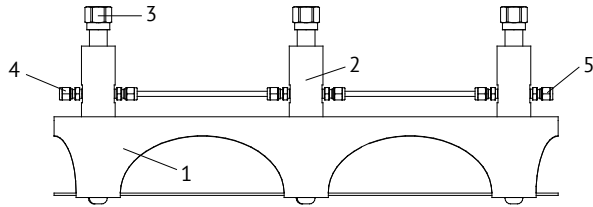

Fig. 5. External view of the collector:

1 – body; 2 – fitting; 3 – connection nut; 4 – connection fitting;
5 – additional output

4.6 GSKA consists of four main parts – control cabinet 1 (Fig. 1), power unit 2, joystick 3, and collector 8. These units are interconnected by: low pressure pipeline 4, high pressure pipelines 5, and two data cables 6. External devices and collector are connected with the help of fitting 7. This design is based on comfortable placement on working place. Power unit as a rule is located on the floor under the table, control cabinet, joystick and collector are located on the table.

4.7 Control cabinet consists of body 1 (Fig.2) made of steel sheet and covered with powder enamel. On the panel there are: system start button 2, operation modes selection lever 3, which permits to switch the system to prepumping mode and pressure regulation mode, also there are: bowl 11 for process liquid and pressure release valve 4. Electric-contact manometer 5 is intended to limit the system pressure at the level of 620...650 bar in case of its erroneous increase. Also it is possible to set approximately the maximum pressure within the limits of 0...620 bar. Emergency stop button 6 serves to switch the system off in case of emergency. In the control cabinet there are: electronic control plate, output valve, ball valve with position sensors, and the control cabinet is designed to control the entire system and change the mode of its operation.

4.8 Power unit consists of body 1 (Fig. 3), inside of which there is a rod pump actuated by electric motor by means of ball-and-screw unit. There is also a motor control unit and a power unit of the whole system. Electronic diagram of the system allows to control the engine in a very wide range of speeds, allowing to get different speeds of pressure change.

4.9 The change of pressure is carried out using a joystick unit, which consists of body 1 (Fig. 4), joystick handle 2, indicators 3, and connection

plug 4 to the system. Indicators serve to display system status and rod final positions. The joystick unit is made remote for convenience of its location in the workplace. The joystick operates in both GSKA operation modes.

4.10 Mode of preliminary pressure generation (is determined by the position of handle 3 (Fig. 2) of the control cabinet). This mode is used to fill the attached manometers or other hydraulic devices with process liquid, by compressing the remaining air in them. In case of the joystick deviation the pump rod begins its movement forward, with speed proportional to the deviation value, and the process liquid is ejected through the output valve into the system and connected manometers or other devices. When the rod reaches its final position, the pressure increase at the output of the system stops and automatically returns to initial position (is not necessary to release the joystick handle) at maximum speed (at this moment process liquid from the bowl 11 (Fig. 2) is absorbed into the cavity of the pump through the inlet valve). When the rod reaches its initial position, it automatically starts to move forward renewing the pressure boost cycle at a speed determined by the position of the joystick. Then the process repeats cyclically. The number of cycles depends on the internal volume of connected manometers or other equipment. When the pressure in the system approaches to the required, it is required to reduce the speed by increasing the deflection angle of the joystick handle. Then stop completely the pressure increase by releasing the joystick, after which the rod automatically returns to the initial position. In this mode, the joystick is only pushing off, that is to increase the pressure.

Attention

It is required to switch the control unit to the regulation mode only when the rod is in initial position.

4.11 Regulation mode (is determined by the position of handle 3 of the control cabinet). This mode is used for precise pressure regulation. In this case, a bypassing of the output valve of the system occurs, which leads to a change in the hydraulic diagram (Fig. 6). The plunger (rod) is able to control the pressure in the system, both to the higher side, and to the smaller side. Also, there is a change of the operation mode of the electronic circuit (changing the drive speeds and movement logic of the rod). The pressure regulation occurs within one stroke. When the joystick handle is pushed off the rod moves forward (green LED activates on the joystick unit — rod forward movement), thus increasing the pressure. When the joystick handle is pulled the rod

moves backward (green LED activates on the joystick unit – rod backward movement), thus reducing the required pressure. In this mode, the range of the rod speeds change is shifted towards lower speeds than in the mode of preliminary pressure generation that allows to set the required pressure very accurately. When the rod reaches final position, it stops, in this case, red LED activates on the joystick unit – «rod final position» or «rod initial position». The rod does not switch automatically to the opposite direction, it is necessary to change the direction of the joystick deviation.

4.12 The collector serves to connect RMI and MI to the system, it can be made with 2, 3 and 4 connection fittings.

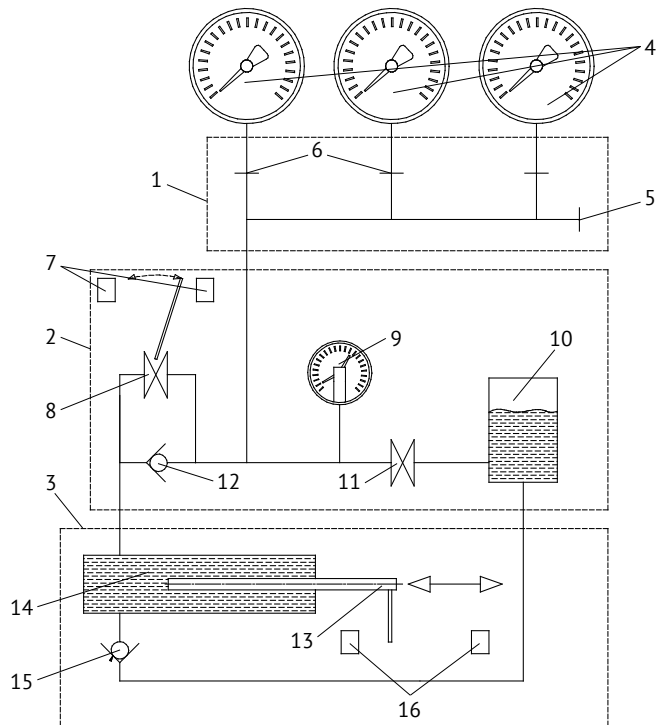

Fig. 6. GSKA hydraulic diagram:

- 1 – collector; 2 – control cabinet; 3 – power unit; 4 – manometers under verification; 5 – additional output; 6 – fitting; 7 – modes sensors;
- 8 – mode selection valve; 9 – protection manometer; 10 – bowl;
- 11 – pressure release valve; 12 – output valve; 13 – rod; 14 – rod cavity;
- 15 – inlet valve; 16 – sensors of initial and final rod position

5 Safety measures

Attention

This section is intended to provide safe operation of the personnel, preservation of GSKA and pressure measuring instruments and other equipment used with it.

5.1 This system allows, in some cases very quickly increase of the pressure up to 600 bar (1 ... 2 s), so that during the operation with it, it is necessary to be very careful and do not to get distracted

5.2 It is prohibited to use the system for operations not indicated in this manual.

5.3 Check that MI are clean and that connecting fittings are serviceable before the installation of the MI under verification.

5.4 Use only standard sealing rings.

5.5 Tighten the conjunctive nuts by hand against the notable stop. Control that connection nuts are tightened on all thread, both from the rack and from the device under verification.

5.6 Tighten the pressure release valve with little effort against the notable stop.

5.7 It is prohibited to exceed the pressure indicated in GSKA manual.

5.8 Disconnect instruments from the system only after complete pressure reduction.

5.9 Carefully inspect the system before activating it, make sure that there are no mechanical damages, that its elements are fastened securely.

5.10 It is prohibited to use system with faulty electric wires and plug.

5.11 Connect the system only to the electric socket which has third grounding contact.

5.12 To prevent the electrocution, connect the system via protective cutout device (PCD) intended for operation current of 16 A and breaking current of 10 or 30 mA.

5.13 It is prohibited to eliminate the system defects if it is connected to the mains or is under pressure.

5.14 It is forbidden to operate with the system when the units bodies are opened.

5.15 If unusual sound or smell appears, immediately switch off the system, disconnect it from electric mains and contact specialists.

5.16 The system repair shall be carried out by specially trained personnel.

6 Preparation for operation

6.1 Unpack the instrument and wipe it with clean rags.

6.2 Install the system in working place and connect it according to fig. 7.

6.2.1 Clamp high pressure fittings (on high pressure pipe) according to appendix 1. Then clamp low pressure fittings (on plastic pipe) with little effort not to crush the pipe.

6.3 Remove the pressure release valve and the bowl cover on the control unit, fill process liquid into the bowl. Disconnect plastic pipe 3 (Fig. 7) from the power unit in connection 6, having blanked it off with a finger. Gradually releasing the air with your finger fill the pipe with process liquid so that about 10 ... 15 cm of the pipe remain unfilled, with quick motion connect the pipe to the power unit and tighten the connection nut using wrench (with little effort, not to crush the pipe).

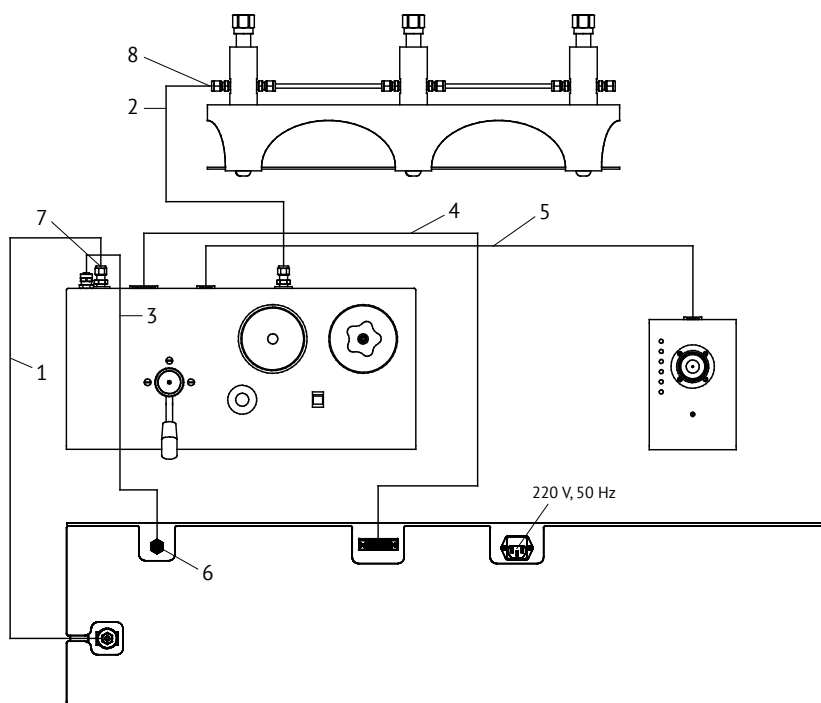

Fig. 7. GSKA units connection diagram:

- 1,2 – stainless pipe with diameter of 6 mm and wall width of 1.5 mm of company DK-Lok, Swagelok or other with corresponding characteristic; 3 – plastic pipe with diameter of 10 mm with wall width of 1 mm of company Camozzi ;
4,5 – data cables; 6, 7, 8 – connection points.

6.4 Install the pressure release valve and close it.

6.5 Loosen connection 7 by unscrewing the fitting nut by 1..2 turns so that the pipe in this connection runs easily, pull the pipe to depressurize the system and wait a few minutes to fill it, observing the level in the bowl. If liquid did not appear in connection 7, activate the system. Switch the mode of preliminary pressure generation, put the system in the motion, observing connection 7. When the process liquid appears in this connection, stop the process and tighten the connection with a little effort (in case of leakage of the process liquid, tighten it with greater effort).

6.6 Disconnect completely connection 8, put under the end of the pipe a low container. Purge the system in the mode of preliminary pressure generation until the air supply termination from the pipe.

6.7 Connect the collector and fill it with process liquid pumping gently.

6.8 If necessary, fill the bowl with process liquid and install the bowl cover.

7 Operation order

7.1 Perform the verification of MI according to verification procedures of MI under verification.

7.2 Check the accuracy of rubber-metal seals installation.

7.3 Establish reference and operation measuring instruments on mounting places of the device by rotating by arm connection nuts counterclockwise until the equipment presses to the sealing rings. Install blank plugs (if necessary). Tighten the connection nuts by hand.

7.4 Shut down pressure release valve.

7.5 Set the mode of preliminary pressure generation (according to item 4.10) to the value of 90...95% of the first verification point, but not more than 30...50 bar. (at higher pressures during the switch to the regulatory mode there is a big drop of pressure in the system)

7.6 Activate the regulation mode. Set the pressure (according to 4.11) in the system equal to the first verification point. Next, in the same mode, set the pressure of next point under verification, and then for other points. The pressure reduction is performed in the same mode. If during the pressure reduction the rod stroke is not enough (red LED activates – «rod initial position»), the residual pressure can be reduced by a smooth opening of the pressure release valve.

7.7 Lower the residual pressure till zero by pressure release valve!

7.8 Remove measuring instruments under verification.

7.9 Switch off the system and disconnect it from electric mains.

7.10 It is recommended to leave the pressure release valve in opened position in the intervals between verifications..

Attention

At each pressure change it is required to make a pause, because the air remaining in the MI is compressed and is heated, increasing the pressure in the system. Upon termination of pressure increase, the air begins to acquire ambient temperature (i.e. begins to cool), reducing in volume and reducing the pressure in the system. It is important to consider it and give some time to the system to acquire thermodynamic equilibrium.

In case of sharp reduction of the pressure, the air remaining in MI is cooled reducing the pressure in the system. Upon termination of pressure reduction, the air begins to acquire ambient temperature (i.e. begins to cool), reducing in volume and increasing the pressure in the system. It is important to consider it and give some time to the system to acquire thermodynamic equilibrium

8 Technical maintenance

8.1 To maintain the device in operation condition it is required to perform daily and routine maintenance.

8.2 Daily maintenance: perform visual inspection, clean it from dirt and dust using dry rags. Check that pipelines and electric cables are serviceable. Check the purity of the process liquid, the integrity of rubber seals and connection fittings.

8.3 Routine maintenance of fluid end of the system: it is required to change process liquid with preliminary washing, for this purpose:

- disconnect completely connection 8, fig. 7, put under the end of the pipe a low container and pump the system in the mode of preliminary pressure generation until the contaminated process liquid ends flowing from the pipe, controlling, in this case, the liquid level in the tank;
- restore connection 8 and add required liquid quantity.

8.4 Routine maintenance of the power unit:

- switch off the system and disconnect it from electric mains;
- lower the pressure in the system till zero by unscrew completely the pressure release valve;

- remove upper cover of the power unit;
- remove old grease from the screw of ball-and-screw unit (BSU) 2, fig. 8;

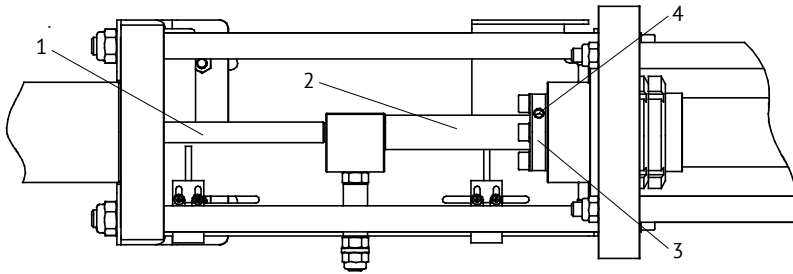

Fig. 8. Power unit with removed cover:

1 – rod; 2 – BCU screw; 3 – BCU nut; 4 – hole for lubrication

- apply new consistent grease Shell GADUS (it is admitted to use grease LITOL – 24 GOST 21150-87;
- using a suitable syringe squeeze grease into hole 4 of BSU nut 3;
- apply to the surface of rod 1 process liquid (in the case of use of transformer oil as a process liquid);
- install upper cover of the power unit.

8.5 Perform the routine maintenance as may be necessary, but not less than 1 time every 3 months.

9 Storage

9.1 GSKA panel storage in laboratory conditions. In case of GSKA panel storage in laboratory conditions it is required to wipe it using clean rags and cover it with plastic cap.

9.2 GSKA panel storage in warehouse room. Prior to install GSKA for storage it is required to wipe it using dry rags, drain process liquid, perform routine maintenance according to items 8.3, 8.4 and pack it in factory package (or its analogue). Store GSKA in dry heated room at air temperature of +5°C minimum and at relative humidity of 80% maximum.

10 Possible troubles and their elimination

Trouble	Cause	Elimination
The system fails to start	No voltage in the network	Supply voltage
	The fuse is burnt out	Replace the fuse
The power unit operates, but the pressure fails to generate	Air in the system	Fill the system according to items 6.3...6.6
The pressure reduces spontaneously (exclude thermodynamics item 7.8)	The manometer seals are faulty	Replace the seals
	Damaged end surface of the manometer fitting	Replace or repair the manometer
The rod does not move forward	The rod is in final position	Displace the rod backward
The rod does not move backward	The rod is in initial position	Displace the rod forward
The system does not react to the joystick position changes	The electronic circuit is faulty	Contact the specialist

11 Warranty

11.1 The manufacturer guarantees GSKA operation provided that operation, storage, and transportation conditions are observed.

11.2 Guaranteed operation period — 18 months.

11.3 Guaranteed warehouse storage period — 6 months.

11.4 Average service life — 8 years minimum.

12 Data on claims

In the case of gauge pressure balance fault, the user should draw up a report about the necessity in repair and about its dispatch to the Manufacturer's address: 2nd Paveletskaya st., 36, Chelyabinsk, 454047, Russia Federation, Alfapascal LLC, phone: +7 (351) 725-74-50, e-mail: q@alfapascal.ru.

13 Acceptance certificate

Automated hydraulic calibrating system (GSKA) serial number _____ corresponds KD AP 048.000.000 and is qualified fit for operation.

Date of manufacturing _____

Responsible person _____

Signature

Surname

Stamp

14 Packing certificate

Automated hydraulic calibrating system (GSKA) serial number _____ was packed in Alfapascal in accordance with KD AP 048.000.000

Packing date

Responsible person

Signature

Surname

Stamp

15 Note

The manufacturer reserves the right to introduce changes to the device design that do not affect basic characteristics without prior notice.

Note

The manufacturer reserves the right to introduce changes to the device design that do not affect basic characteristics without prior notice.

Appendix 1

Installation instructions: fittings DK-LOK of size 1" (25 mm) and less.

These instructions are applied both to standard DK-LOK fittings and Z-series fittings. DK-LOK fittings are supplied manually screwed together and ready for use. No need to disassemble fittings before installation.



Step 1. Insert a pipe into DK-LOK fitting

1. Make sure, that the end of the pipe rests against internal grooves of the fitting
2. Tighten the nut manually
3. Mark the nut at the 6 o'clock position

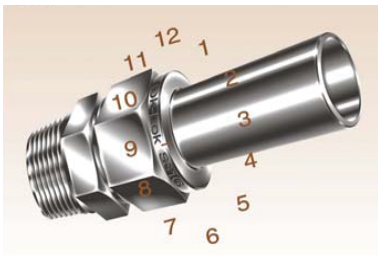

Step 2. Tighten the nut by additional $1\frac{1}{4}$ turns with a wrench up to the 9 o'clock position, firmly holding the fitting in its position with another wrench.

1. Tighten the nut by $\frac{3}{4}$ turns up to the 3 o'clock position for $\frac{1}{16}$ ", $\frac{1}{8}$ " and $\frac{3}{16}$ "; as well as for 2, 3 and 4 mm fittings.

DK-LOK — installation for high pressures and reliability-critical applications

Step 1. After having the pipe inserted (it shall rest against internal grooves of the fitting) tighten the nut with a wrench until pipe stops turning and moving in axial direction under manual effort.

- Mark the nut at the 6 o'clock position.

Step 2. Tighten the nut by additional $1\frac{1}{4}$ turns with a wrench up to the 9 o'clock position.

- Tighten the nut by $\frac{3}{4}$ turns up to the 3 o'clock position for $\frac{1}{16}$ ", $\frac{1}{8}$ " and $\frac{3}{16}$ "; as well as for 2, 3 and 4 mm fittings. Re-assembly instruction: DK-LOK connections are designed for multiple use. Before re-assembly, make sure that all parts of the connection are clear and have no defects.