

Table of Contents

1	Purpose.....	2
2	Technical Characteristics	2
3	Scope of Supply, pcs	4
4	Instrument Design and Principle of Operation	4
5	Safety Precautions.....	10
6	Preparation for Operation	11
7	Operation Procedure	14
8	Maintenance.....	16
9	Storage	19
10	Troubleshooting	19
11	Test methods	20
12	Warranty obligations.....	20
13	Claim Details	20
14	Acceptance certificate.....	20
15	Package certificate.....	21
16	Note.....	21
17	Disposal.....	21

This operation manual (hereinafter — OM) covers differential pressure balances MPD with the top limit of gauge pressure measurement up to 16 MPa. OM includes the purpose, technical parameters, description of the principle of operation, structure, as well as the information required to proper operation of differential pressure balance, maintenance, and storage.

Differential pressure balance shall be operated by trained personnel with required qualification in strict compliance with its purpose and requirements of OM.

1 Purpose

1.1 Differential pressure balance with simple piston directly loaded with loads is designed for generation and measurement of two values of gauge pressure of liquids and their difference.

1.2 Differential pressure balance is used for verification and calibration of measurement transducers of pressure difference and differential pressure gages.

1.3 Separating chambers shall be used for verification or calibration of MI of oxygen design.

2 Technical Characteristics

Table 1. Technical characteristics of MPD

	MPD 6...16	MPD 25...160
Nominal area of piston, sm ²	1	0,5
Top limit of measurement of gauge pressure, MPa (kgf/cm ²)	0,6...1,6 (6...16)	2,5...16 (25...160)
Low limit of measurement of gauge pressure, MPa (kgf/cm ²)	0,04 (0,4)	0,02 (0,2)
Pressure difference measurement range, MPa (kgf/cm ²)	0,001...0,1 (0,01...1)	0,001...0,1 (0,01...1)
The limit deviation from nominal value of piston effective area, %	±0,4	±0,8
Piston stroke, minimum, mm		10

	MPD 6...16	MPD 25...160
Limits of gauge pressure measurements allowable tolerance, % ¹		
accuracy class 0.005		± 0.005
accuracy class 0.01		± 0.01
accuracy class 0.02		± 0.02
accuracy class 0.05		± 0.05
Limits of pressure difference measurement allowable tolerance, Pa		
accuracy class 0.005		± (5+0,00005·dP)
accuracy class 0.01		± (10+0,0001·dP)
accuracy class 0.02		± (20+0,0002·dP)
accuracy class 0.05		± (50+0,0005·dP)
Piston downstroke rate, mm/min, maximum		
accuracy class 0.005	0,4	0,2
accuracy class 0.01	0,4	0,2
accuracy class 0.02	0,4	0,2
accuracy class 0.05	0,6	0,4
Piston free rotation continuation, min, minimum		
accuracy class 0.005	6	10
accuracy class 0.01	6	6
accuracy class 0.02	4	5
accuracy class 0.05	3	4
Discrimination threshold, Pa, maximum		
accuracy class 0.005		$P_{\max} \cdot 0,1 - 0,005/100$
accuracy class 0.01		$P_{\max} \cdot 0,1 - 0,01/100$
accuracy class 0.02		$P_{\max} \cdot 0,1 - 0,02/100$
accuracy class 0.05		$P_{\max} \cdot 0,1 - 0,05/100$
Material of cylinder and PCA piston	Tungsten carbide	
Working medium	Kerosene ²	
Working liquid volume, cm ³ , maximum	250	
Overall dimensions, LxWxH, mm, maximum	500×820×400	
Weight (without loads), maximum, kg	50	

¹ In the main range of measurements from $0.1 P_{\max}$ to P_{\max} the tolerance is regulated in % of measured value; in additional measurement range from P_{\min} to $0.1 P_{\max}$ the tolerance is regulated in % of $0.1 P_{\max}$ (where P_{\max} is upper measurement limit; P_{\min} is lower measurement limit); dP is measured pressure difference.

² Recommended kerosene TC-1 or PT as per GOST 10227-86.

3 Scope of Supply, pcs

Basement with pressure generator (UCD)	1
Piston-cylinder assembly (PCA)	1
Balance piston system (BPS)	1
Set of loads reduced to nominal weight value, kg.....	1
Set of loads for balancing reduced to nominal weight value, kg.....	1
Set of balance weights (1–500 g) F1 as per GOST OIML R 111-1.....	1
Set of balance weights (1–500 mg) F1 as per GOST OIML R 111-1.....	1
Statoscope (device for pistons position observation)	1
Operation Manual	1
Calibration Certificate	2
Calibration certificate for set of loads	2
Calibration certificate for balance weights (set of weights).....	2
Plugs for MI racks	2
Level	1
Press handwheel lever	6
Manual pump lever.....	1
Hexagonal wrench S 5	1
Hexagonal wrench S 6	1
Set of spare O-rings.....	1

4 Instrument Design and Principle of Operation

4.1 Differential pressure balance view is shown on figure 1.

Operation of differential pressure balance is based on the principle of reproduction of the set values of gauge pressure with two piston systems (PCA and BPS) with simple free pistons. After balancing piston systems, connection between them is interrupted by means of closing valve 10 and putting weights on PCA corresponding to the load being reproduced (measured) of pressure difference. PCA is repeatedly balanced by means of press. Pressure equal to pressure difference generated by two piston systems (PCA and BPS) was supplied to verified (calibrated) MI connected to BPG.

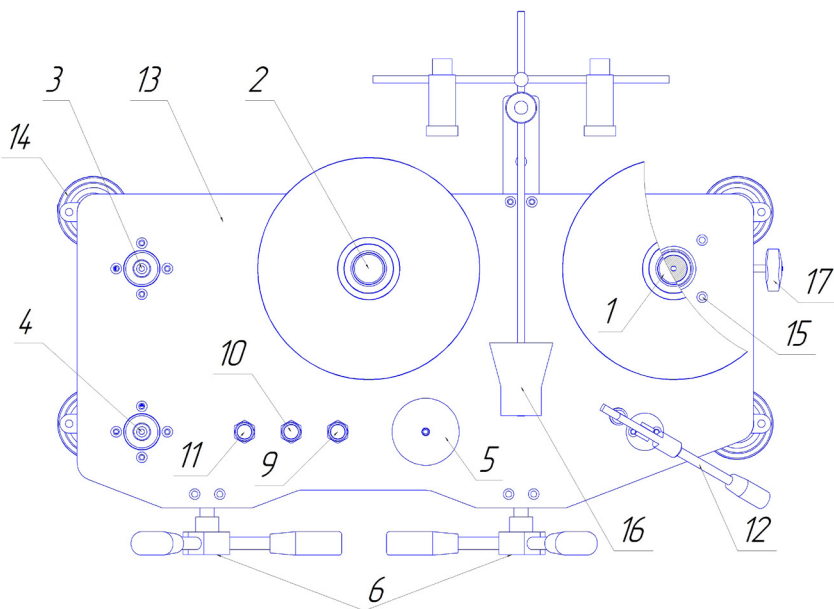

Fig. 1. Differential pressure balance with piston systems
for MP-D-25...MP-D-160

- 1 — MPS (metering piston system); 2 — BPS (balancing piston system);
 3 — rack for positive pressure supply; 4 — rack for negative pressure supply;
 5 — sleeve for working fluid; 6 — press; 9 — stop valve; 10 — shut-off valve;
 11 — stop valve; 12 — manual pump; 13 — basement; 14 — support;
 15 — regulating screw; 16 — statoscope; 17 — additional stop valve.

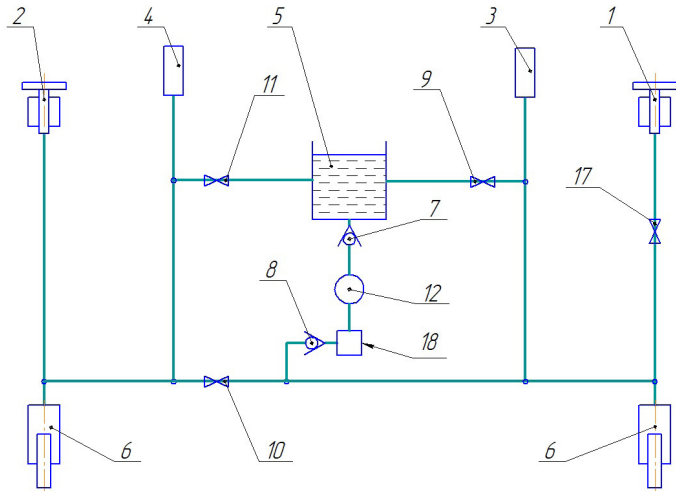

Fig. 2.

- 1 – MPS (metering piston system); 2 – BPS (balancing piston system);
 3 – rack for positive pressure supply; 4 – rack for negative pressure supply;
 5 – sleeve for working fluid; 6 – press; 7 – non–return valve;
 8 – pressure valve; 9 – stop valve; 10 – shut–off valve; 11 – stop valve;
 12 – manual pump; 17 – additional stop valve; 18 – filter.

4.2 Differential pressure balance consists functionally of four parts: pressure generating device, two piston systems, two sets of weights and statoscope. Basement 13 (Fig. 1) of differential pressure balance is made as a steel plate equipped with four regulated supports 14. Presses 6 are volume regulators for accurate setting and adjustment of pressure. Manual pump is made as a separate unit 12 and consists of lever press connected with valves 7, 8 (Fig. 2). In order to improve operation reliability, as well as for avoiding the unit damage, hydraulic diagram includes fine filter 18. Sleeve for working fluid 5 is placed on the basement 13 (Fig. 1). MPS 1 is installed on right rack (rack for MPS), BPS 2 – on left rack, verified (calibrated) MI is installed directly on rack 3 and 4 by means of connecting nuts. The regulation of MPS vertical position is done by means of four screws 15 for fixation of regulated rack; regulation of vertical position of BPS is done with four supports 14 (BPS is regulated first, then MPS is regulated). Slow regulation of position (emergence) of MPS and BPS is done with press 6 handwheels. Working fluid is supplied to the units through connecting tubes connected by

fittings. Process screws for working fluid discharge are provided at the bottom of press 6 main units.

4.3 Structures of piston systems are presented on figures 3 and 4 depending on the design of differential pressure balance.

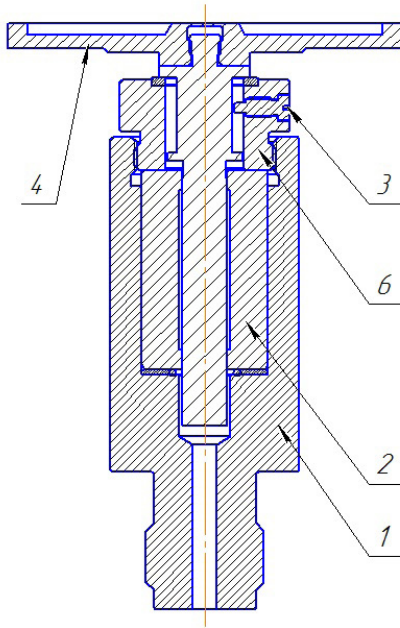

Fig. 3. Structure of piston systems (MPS and BPS) for MP-D-6...MP-D-16

- 1 – MPS housing; 2 – cylinder; 3 – lock screw;
- 4 – piston with load receptor; 6 – nut.

Piston systems MP-D-6...MP-D-16 (Fig. 3) consist of the housing, cylinder, lock screw (preventing piston exit out of cylinder), load receptor with piston, nut (fixing cylinder in MPS housing).

Statoscope is provided on piston systems MP-D-6...MP-D-16 for determination of piston balanced position.

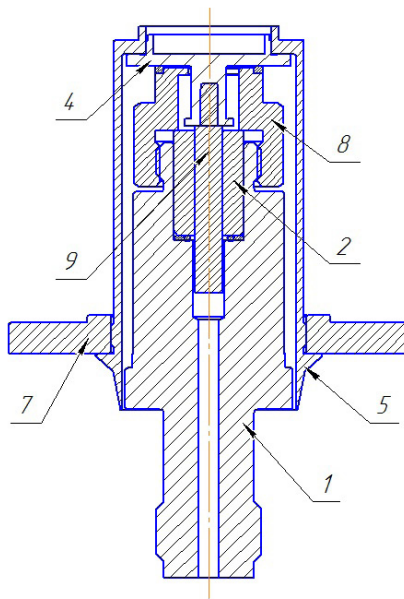

Fig. 4. Structure of piston systems (MPS and BPS) for MP-D-25...MP-D-160
 1 – MPS housing; 2 – cylinder; 4 – load receptor; 5 – bell body;
 7 – bell plate; 8 – nut; 9 – piston.

Piston systems MP-D-25...MP-D-160 (Fig. 4) consist of the body, cylinder, load receptor and piston. In contrast to PS MP-D-6...MP-D-16, these PS fix piston for preventing its exit out of the cylinder with eccentric nut 8.

Statoscope is used for determination of the piston balanced position.

4.4 Two piston systems included in the differential pressure balance are absolutely similar in structure and accuracy having different functional purpose: one system – MPS (metering piston system) serves for making measurements; the other one – BPS (balancing piston system) serves for balancing.

The loads are made in the form of flat rings of different diameters.

Sets of loads included in the instrument set ensure setting of gauge pressure at the entire range of the instrument design. As well as for generating differential pressure.

Sets of weights included in the instrument scope ensure setting of pressure difference, as well as for PS balancing.

Balancing cups are provided for placing weights on the loads, which can be installed on the bell, or the loads of MP-D-25-160 design. Or the cups of any other design for MP-D-6-16 that are placed only on the loads.

4.5 Differential pressure balance operates in the following way. By means of the manual pump 12 (Fig. 1) the working fluid is pumped from sleeve 5 to the main unit, presses 6, racks of MPS 1, BPS 2, 3 and 4 with installed metering instrument. Manual pump 12 is required for preliminary air compression in connected MI for reducing its volume and for system purging. The value of pressure generated with manual pump depends on the installed MI and shall not exceed 3 MPa. Then, by rotating one of the press 6 handwheels clockwise the required pressure is slowly generated up to emergence of one of the piston systems (MPS or BPS). Then MPS and BPS are balanced with weights. After balancing piston systems connection between them is interrupted by closing shut-off valve 10 (Fig. 1 and 2) and load is applied to MPS that corresponds to the reproduced (measured) pressure difference. Piston systems are balanced again with presses 6. Pressure equal to pressure difference generated by two piston systems MPS and BPS was supplied to verified MI connected to racks 3 and 4. Statoscope is used to check balanced position of piston systems. Press 6 handwheel shall be rotated counterclockwise to reduce pressure. Stop valves 9 and 11 are provided for residual pressure relief.

5 Safety Precautions

Attention

- 5.1 The section is intended for the personnel safe operation, safekeeping of MP-D and the pressure metering devices used with the unit.
- 5.2 Pressure exceeding the top limit of measurements for this model of MP-D shall not be generated.
- 5.3 Protect loads against mechanical damages.
- 5.4 Do not allow knocks or impacts on MPS.
- 5.5 Differential pressure balance must not be used for any operations not specified in the manual.
- 5.6 Use only standard O-rings. Installed PS and adapters (if used) shall be tightened with wrench, with minor effort sufficient for their stable position.
- 5.7 Other MI shall be installed on adapter using connecting nut that is tightened manually to sensible stop.
- 5.8 Pressure relief vales 9, 11 and stop valve 10 shall be tightened with minor effort.
- 5.9 For degreasing and processing of individual parts with gasoline (B 70 — TU 38.101913-82, Galosha — TU 38.401-67-108-92, NEFRAS — GOST 8505-80), it is necessary to observe safety measures for working with gasoline.
- 5.10 Place loads on the hard flat and clear surface next to MP-D.
- 5.11 It is necessary to remove and install loads PS with two hands one by one piece.
- 5.12 It is prohibited to install loads on a transitional plate, the total weight of which exceeds the weight of the bell.
- 5.13 Observe safety regulation when operating combustible liquids in the instrument.

6 Preparation for Operation

6.1 Unpack differential pressure balance and wipe it down with clean cloth.

6.2 Install PG on the rigid, stable basement avoiding bending, shaking and vibrations. If required, fix with screws (are not included in the standard scope of supply).

6.3 Any conditions generating heat irradiation and fluctuations of the air temperature shall be avoided next to MP-D.

6.4 Disassemble piston systems.

6.4.1 For MP-D-6...MP-D-16: unscrew lock screw and remove piston with the load receptor. Unscrew nut from the piston system body and remove cylinder.

6.4.2 Disassembling of PS MP-D-25...MP-D-160 includes: unscrew nut 8 (Fig. 4) and remove load receptor with piston, together with unscrewed nut. Then remove nut from piston. Then remove cylinder.

Attention

Protect parts of piston systems against damage.

6.5 Then wash the parts of piston system in clear gasoline (B 70 — TU 38.101913-82, Galosha — TU 38.401-67-108-92, Nefras — GOST 8505-80) and dry. Clean working surfaces of piston and cylinder with white lace or flimsy (GOST 3479-85) or lint-free tissue soaked in pure ethyl alcohol (GOST 10121-76) or chemically pure isopropyl alcohol (GOST 9805-84) and wipe dry with force with clean lint-free tissue. Look at cylinder channel, it should not remain nap, if necessary, remove it with a tampon made of cotton wool. When putting piston into cylinder do not apply an efforts, wet with working fluid in advance, piston should freely slide in the cylinder without any signs of friction. If there is no easy stroke of piston in the cylinder, repeat washing of the piston and cylinder.

6.6 After washing install cylinders back to the piston systems bodies. For MP-S-6-16 screw the nuts 6 (Fig. 3) on the piston systems bodies.

6.7 Install special sealing in the mounting slots of MPS and slots of the instruments leads for verified MI. Install on PG-MPS, BPS. Install adapters on the rack of verified MI.

6.8 Tighten PS bodies and adapters with wrench with minor effort for their stable position.

6.9 Rotate press handles counterclockwise to move plunger rods in extreme position.

6.10 Fill-in working fluid to sleeve to the level not exceeding the maximum one (notch on plastic sleeve).

6.11 Unscrew needle 1 (Fig. 5) on manual pump for 1/2 turn. Slowly pump the manual pump until air bubbles stop coming out from needle 1 thread. After that screw needle 1 with minor effort.

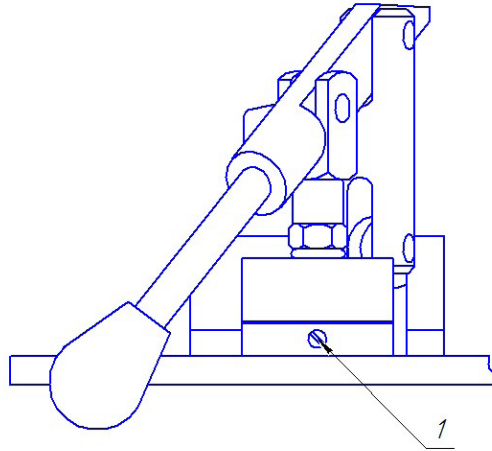

Fig. 5.

1 – Needle for instrument pumping
(air release from the manual pump cavity).

6.12 Close pressure relief valves 11 and 9 (Fig. 1). Leave valve 10 open.

6.13 Pump working fluid with slow motions of manual pump into the system making sure that working fluid is not splash out from PC bodies and the holes of adapters, permanently control fluid level in the sleeve (tap, if required). When working fluid level in the adapter holes is increased to the top edge, connecting nuts, rubber-metal seals and plugs shall be installed.

Continue pumping working fluid until it appears in the PS cylinders channels. Close valve 10. Rotate appropriate handwheel, lift fluid level in one PS to the top cylinder surface with minor outflow. Then lift fluid level in the second PS.

6.14 Lubricate PS piston with working fluid and carefully move the piston bottom end to the hole in appropriate cylinder and carefully put in. For MP-D-25-160 nuts 8 (Fig. 4) are eccentric (without lock screw).

Therefore, nut 8 shall be put on piston first for PS assembly.

Attention

Do not apply effort to piston for its putting into cylinder as fluid in the cylinder channel prevents this. Use appropriate handwheel to slowly reduce fluid level in the cylinder channel and to simultaneously put down the piston.

6.15 After this, screw lock screw on PS body or the nut (in case of design without lock nut).

6.16 Then repeat procedure of piston putting in on the second PS in the same manner.

6.17 Adjust vertical position of piston systems. For this, put level from the instrument set on the load receptor of BPS and adjust its verticality using PG supports.

6.18 Put level on the load receptor of MPS and adjust its verticality with regulating screws 15 (Fig. 1).

6.19 After this, plugs can be removed from MI adapters.

6.20 Assemble bell having put bell plate on the bell body (if it is included in the scope of supply of differential pressure balance).

6.21 Assemble the unit for observation position of pistons (statoscope).

6.22 Install basement 7 (Fig. 6) of the unit for piston position observation on the basement of differential pressure balance. Screw rack 5 on the back side of basement of the unit for piston position observation.

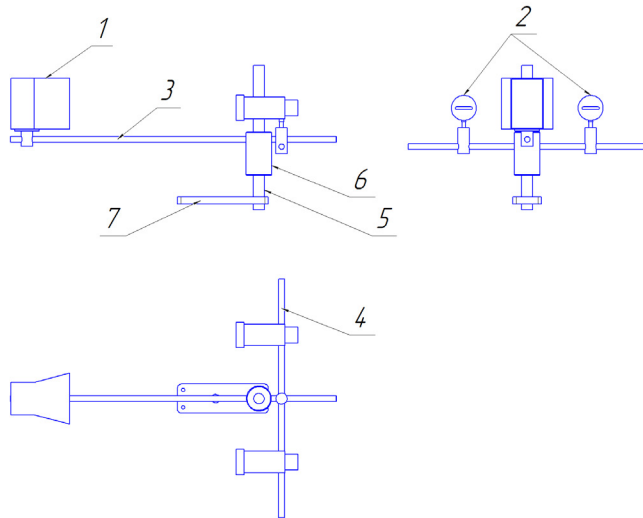

Fig. 6. Statoscope

1 – screen; 2 – lighting fixture; 3, 4 – guiding rods; 5 – rack;
6 – bushing; 7 – statoscope basement.

6.23 Fix bushing 6 on rack 5. Install rod 3 in bushing 6. Install short rod at the other side of bushing 6 and fix rod 4 on it. Fix screen 1 on rod 3 edge, fix lighting fixture 2 on rod 4 (as shown on figure 6).

6.24 Adjust arrangement of lighting fixtures so that shadows of loads can be seen on the screen 1 scale.

7 Operation Procedure

7.1 Verification of differential MI shall comply with the methods of verification of specific MI.

7.2 Thoroughly read and understand safety regulations when operating differential pressure balance.

7.3 Prepare differential pressure balance for operation.

7.4 Install press 6 (Fig. 1) in the middle position.

7.5 Unscrew shut-off valve 10 for 1/2 turn (not more than 2 turns).

7.6 Stop valves 9 and 11 shall be closed.

7.7 Install verified (calibrated) MI: low pressure side (minus) to rack 4, high pressure side (plus) to rack 3.

7.8 Install loads for measurements on MPS that correspond to the current static pressure, install on BPS the loads for balancing MPS.

7.9 Rotate press handwheel (clockwise — to increase pressure; counterclockwise — to decrease pressure) to slowly change pressure until piston of one of the piston systems emergence. After this, touch loads with both hands and slightly rotate them (clockwise) with the rate about 30 rpm. Balance both piston systems in working position. Control by means of statoscope.

Attention

Do not apply asymmetric loads on the loaded piston systems to avoid their damage.

Do not allow impacts of the load receptor of piston system with top pt bottom stops due to sharp change of generated pressure as it can result in piston system damage.

7.10 Screw shut-off valve 10 with minor effort. Add loads on MPS for measurement corresponding to the first point of differential pressure.

7.11 Balance piston systems using press 6 and statoscope.

Attention

When using weights from the set. Install them on the balance cup as symmetric and close to rotation axis of piston systems as possible (to avoid effect of centrifugal force).

Attention

Do not either install or remove loads during their rotation to avoid damage of piston systems. Install and remove loads only when pressure is reduced for the value higher than the load removed for preventing spontaneous piston lifting and piston system failure.

Useful information: Do not allow contamination of loads and load receptor.

7.12 After measurements in this point rotate press handwheel to put down load receptor with installed loads to the bottom stop.

7.13 For setting the next value of test pressure repeat items 7.8–7.12 accordingly.

7.14 After all measurements with installed verified (calibrated) MI fully unscrew counterclockwise both handwheels of press 6, then reduce pressure to zero by opening stop valves of pressure relief 9 and 11.

7.15 Between measurements stop valves 9 and 11 shall be open.

7.16 Remove verified (calibrated) MI.

7.17 When BPS is off (valve 10 is closed) differential pressure balance can be used for gauge pressure measurements.

8 Maintenance

8.1 In order to keep the pressure balance serviceability daily and routine maintenance is required.

8.2 Daily maintenance includes visual inspection, cleaning from dust and dirt with clean cloth (soaked in pure gasoline if required (B 70 – TU 38.10191382, Galosha – TU 38.401-67-108-92, Nefras – GOST 8505-80)). Availability of lubricant on the surface of manual pump rod, in the units of rotation and on the press screws surface. If it is absent or insufficient, lubricate surfaces of press screws and manual pump rotation units with grease Shell (GADUS S2 V220AC 2) or equivalent and the surface of rod of manual pump with working fluid used in the instrument.

8.3 Routine maintenance includes replacement of working fluid with preliminary washing.

8.3.1 Fully unscrew drainage screws at the bottom of press units with hexagonal wrench S6 having preliminary installed differential pressure balance on wooden supports 100x100, 50-100mm high and having put low tanks (not included in the scope of supply).

8.3.2 Close pressure relief valves 9, 11 (Fig. 1). Open valve 10.

8.3.3 Pump with manual pump until total stop of the working fluid outflow.

8.3.4 Fill-in clean working fluid in the sleeve.

8.3.5 Repeat operations 8.3.3 and 8.3.4 until not working fluid is coming out of the drain outlet.

8.3.6 Screw drain screws with rubber-metal seals with minor efforts to sensible stop sufficient for preventing spontaneous unscrewing.

8.3.7 Remove and disassemble piston systems. Disassembly shall comply with PS structure. Remove pistons and cylinders.

Attention

Protect parts of piston systems against damage.

8.3.8 Then wash the parts of piston system in clear gasoline (B 70 – TU 38.101913-82, Galosha – TU 38.401-67-108-92, Nefras – GOST 8505-80) and dry. Clean working surfaces of piston and cylinder with white lace or flimsy (GOST 3479-85) or lint-free tissue soaked in pure ethyl alcohol (GOST 10121-76) or chemically pure isopropyl alcohol (GOST 9805-84) and wipe dry with force with clean lint-free tissue. Look at cylinder channel, it should not remain nap, if necessary, remove it with a tampon made of cotton wool. When putting piston into cylinder do not apply an efforts, wet with working fluid in advance, piston should freely slide in the cylinder without any signs of friction. If there is no easy stroke of piston in the cylinder, repeat washing of the piston and cylinder.

8.3.9 Install piston systems on appropriate racks, fill-in with working fluid and pump. According to items 6.13–6.16.

8.3.10 Adjust vertical position of piston systems. In accordance with item 6.17.

8.3.11 Lubricate surface of manual pump rod, rotation units and press screws surfaces as specified above.

8.3.12 Disassemble and wash fine filter intended for filtration of working fluid when it is pumped through cavities of manual pump to the main cavities of PG. Filter is installed under the plate-basement of differential pressure balance, at the right side, on welded corner. Internal structure of filter is shown on figure 7.

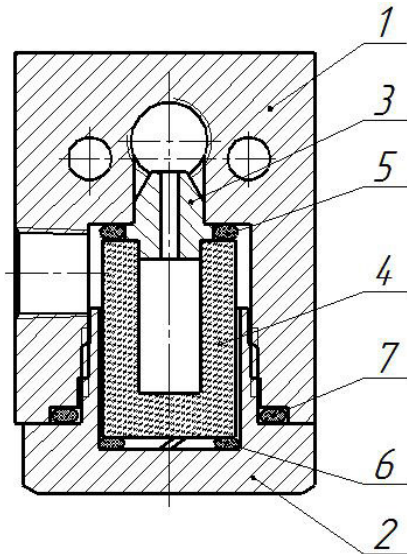

Fig. 7. Filter.

- 1 – filter body; 2 – cover; 3 – centering bushing; 4 – filter element;
 5, 7 – rubber O-ring; 6 – rubber pressing ring.

Unscrew cover 2 (figure 7) from filter and remove filtering element 4. Wash filter element, filter cover and wipe inner cavity of filter with calico soaked in pure gasoline (B 70 – TU 38.101913-82, Galosha – TU 38.401-67-108-92, Nefras – GOST 8505-80) and dry. After this, install filter element, rubber seals and filter cover in reverse order (if required, replace rubber seals and filter element).

Attention

Screw filter cover with minor efforts until its contact with filter body. Sealing results from compression of rubber rings and does not depend on the tightening effort.

Rubber ring 6 installed under filter element shall be cut.

8.4 Routine maintenance shall be performed as required, but no less than once a month.

9 Storage

9.1 Differential pressure balance storage in laboratory conditions.

9.1.1 When storing the differential pressure balance in laboratory conditions, wipe it with clean cloth and cover it with a polyethylene cap.

9.1.2 Differential pressure balance storage in warehouse conditions.

9.1.3 Prior to put differential pressure balance for storage the routine maintenance shall be done according to items 8.3–8.3.12. Then drain working fluid from PG of MPS and BPS.

9.1.4 Wipe down differential pressure balance with clean cloth and pack in factory package (or similar one).

9.1.5 Box with differential pressure balance shall be stored according to indicated handling signs.

9.1.6 Differential pressure balance shall be stored in dry, heated room at the temperature no lower that $+5^{\circ}\text{C}$ and relative air humidity $60\pm 20\%$.

9.1.7 Repeat preservation (unpack, fill-in clean working fluid, pump, drain working fluid, lubricate, pack) once every 6 months.

10 Troubleshooting

Malfunction	Cause of the malfunction	Repair method
Pressure is not generated with manual pump	O-ring under PS or other MI is damaged or incorrectly installed	Replace or re-install O-ring
	Face surface of nozzle of PS or other MI is damaged.	Repair damage or replace fault MI
	Manual pump sealing is damaged	Manual pump sealing is damaged
	Manual pump non-return valve is damaged	Contact a specialist
	Non-return valve of the main unit is damaged	Contact a specialist
	Air penetrated to the pump	Repeat item 6.11 of OM
Leakage from under manual pump rod	Manual pump sealing is damaged	Replace the seal
Leakage from under the main rod	Main rod sealing is damaged	Replace the seal

11 Test methods

11.1 Verification of differential pressure balance MP-D of all designs shall comply with the method of verification of MP AP-01-2016 «Pressure balances MP and MGP. Calibration methods».

11.2 Differential pressure balance MP-D are subject to the state verification. Frequency of calibration - once every 2 years.

12 Warranty obligations

12.1 The manufacturer guarantees compliance of the differential pressure balance with the requirements of TU 4212-00791357274-2016, provided that the customer observes the conditions of transportation, storage, installation, and operation.

12.2 The warranty service life is 18 months from the date of the differential pressure balance shipment to the customer.

12.3 The average service life is at least 10 years.

12.4 Warranty does not cover any sealing damages as well as defects due to intensive operation.

13 Claim Details

In case of a failure, prepare a certificate of required repair and submit it to the following address: «Alfapascal» LLC, 36, 2nd Paveletskaya, Chelyabinsk, 454047, Russia, phone: +7 (351) 725-74-50, e-mail: q@alfapascal.ru

14 Acceptance certificate

Differential pressure balance MP-D _____ accuracy class _____
factory number _____ complies with TU 4212-007-91357274-2016
and has been approved as fit for operation.

Date of issue

Responsible person _____
Signature _____ Surname _____

LS

15 Package certificate

Differential pressure balance MP-D _____ accuracy class _____
factory number _____ was packed at «Alfapascal» LLC in accordance
with TU 4212-007-91357274-2016.

Date of packing _____

Responsible person _____
Signature _____ Surname _____

LS

16 Note

16.1 Manufacturer reserves the right to make changes of the instrument structure without deteriorating its metrologic properties.

17 Disposal

17.1 Differential pressure balance MP-D does not contain any precious metals or harmful substances that require special methods of disposal. Upon completion of the service life differential pressure balance MP-D shall be exposed to preparation and removal for disposal. The regulatory and technical documents for disposal of ferrous and non-ferrous metals shall be observed that are valid at the operating company.