

SITRANS F flowmeters

SITRANS F VA

SITRANS FVA250 variable area meter

Overview



SITRANS FVA250 variable area meter

Application

The SITRANS FVA250 variable area meters with a standard length of 250 mm (9.84 inch) and their completely metal design can be used to measure many different types of liquids and gases passing through closed piping. The robust design means that they can also be used in harsh conditions. Different types of flanges, liners and float materials satisfy the requirements of the pharmaceutical and chemical industries.

The measured value is displayed directly on the scale, and output via a switch contact or as a current output (HART or PROFIBUS PA).

The SITRANS FVA250 is primarily used in the following industries:

- Chemical industry
- Water
- Power generation and distribution

Special features

- Standard design available at short notice
- Robust all-metal fitting with impact-resistant housing cover
- Can also be used for corrosive and flammable media
- Use possible at high pressures and temperatures
- Product and percentage scales
- Can be optionally fitted with heating and cooling sheaths
- Contamination-insensitive guiding of float

Design and mode of operation

Like the other units in the SITRANS F VA range, the SITRANS FVA250 operates according to the variable-area flow tube principle: the flowing medium lifts the conical float in the flow tube. The annular gap is then increased until there is an equilibrium between the buoyant force of the medium and the force due to the weight of the float. The height of the float is directly proportional to the flow quantity. The movement of the float is transmitted by a magnet to a slave magnet in the display unit outside the flow tube.

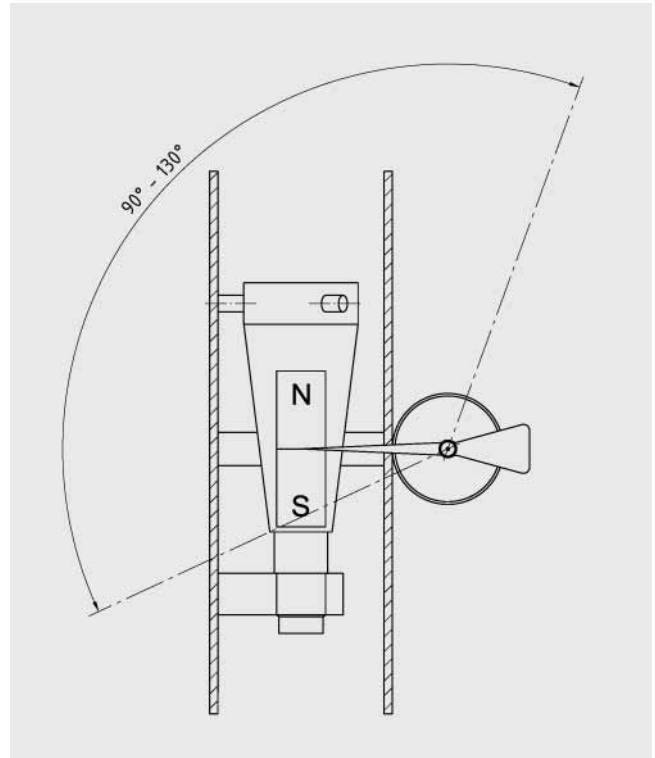

Flow tube/tube angle

Float damping

A float damping is generally recommended

- for gas measurements.
- if air pockets cannot be completely prevented in the medium.
- if the pipelines are subject to knocking caused by delays in the flow rate, e.g. due to fast throttling or when the pipe is shut off.
- if turbulence, pulsations or other instabilities cause the float to oscillate.
- when it is not possible to slowly build up the flow pressure.
- when it is not possible to prevent vibrations in the pipeline.

Technical specifications

Application	See page 4/340
Design and mode of operation	See page 4/340
Measuring principle	Variable area flowmeter
Input	
Measuring range	See table on page 4/343
Pressure rating	PN 10 ... PN 40 (145 ... 580 psi) depending on version (see table on page 4/343)
Flow	upwards
Dimensions for measured variables	l/h, from 4000 l/h (17.6 USgpm) in m ³ /h
Rated conditions	
Mounting	vertical
Ambient temperature	
• With local display	-40 ... +80 °C (-40 ... +176 °F)
• With limit transmitter	-40 ... +65 °C (-40 ... +149 °F)
• With HART, PA output	-40 ... +70 °C (-40 ... +158 °F)
Medium conditions	
• Measuring accuracy	
- For liquids	± 1.6%
- For gases	± 2.0%
• Temperature of medium	See page 4/343
Design	
Flanges	EN 1092-1, ANSI
Material	
• Fitting	Stainless steel, mat. No. 1.4404/316L
• Float	Stainless steel, mat. No.1.4404/316L, Hastelloy, PTFE
• Wetted parts materials	Stainless steel mat. No. 1.4404/316L, PTFE, C 22.8, Hastelloy depending on version
Degree of protection (display unit)	
• Display unit made of aluminium	IP65
• Display unit made of stainless steel	IP66
Electromagnetic immunity	
• EN 61000-6-2: 1999	Interference immunity industrial environment
• EN 50081-1	Emitted interference residential environment
• EN 55011: 1998 + A1: 1999	Group 1, Class B
• NAMUR recommendation	NE 21

Classification according to pressure equipment directive (DGRL 97/23/EG)

	Order No. 7ME5822- 7ME5823-	Permissible media	Category
DN 15	xAxxx-xxxx	Gases of fluid group 1 and liquids of fluid group 1	Article 3.3
DN 20	xFxxx-xxxx		Article 3.3
DN 25	xBxxx-xxxx		Article 3.3
DN 32	xGxxx-xxxx		III
DN 40	xHxxx-xxxx		III
DN 50	xCxxx-xxxx		III
DN 65	xJxxx-xxxx		III
DN 80	xDxxx-xxxx		III
DN 100	xExxx-xxxx		III

Technical specifications of contacts

Limit transmitter	
Switching principle	Inductive contact, single contact and twin contact
Connection	M20x1.5
Auxiliary power supply	DC 8 V
Self-inductance	500 µH
Self-capacitance	80 nF
Ambient temperature	
• When used in non-hazardous locations	-40 ... +65 °C (-40 ... +149 °F)
Explosion protection	II 2G EEx ia IIC T6 - T4
EC-Type Examination Certificate for Directive 94/9/EG	PTB 99 ATEX 2219 X
Electric remote transmitter, signal output HART	
Connection	2 wire connection
Auxiliary power supply	DC 14 ... 30 V
Output	4 ... 20 mA
Load	min. 250 Ω
Ambient temperature	
• When used in non-hazardous locations	-40 ... +70 °C (-40 ... +158 °F)
Explosion protection	ATEX II 2G EEx ia IIC T6
EC-Type Examination Certificate for Directive 94/9/EG	DMT 00 ATEX E 075
Electric remote transmitter, signal output PROFIBUS PA	
Auxiliary power supply	DC 10 ... 25 V
Basic current	< 16.5 mA
Fault current	< 18 mA
Transfer rate	31.25 kBaud
Ambient temperature	
• When used in non-hazardous locations	-40 ... +70 °C (-40 ... +158 °F)
Explosion protection	ATEX II 2G EEx ia IIC T6
EC-Type Examination Certificate for Directive 94/9/EG	DMT 00 ATEX E 075

FunctionDevice setting*Limit sensor (inductive contact)*

The measuring instrument is supplied as ordered ready for operation. Limit sensors are preset to the required values. If you have not stipulated any particular specifications, the basic settings are as follows:

- 1 contact device:
Min. contact switching point at 10 % falling flow rate. (damped/closed-circuit operation)
- 2 contact devices:
Min. contact switching point at 10 % falling flow rate and max. contact switching point at 90 % rising flow rate

Adjusting the limit sensors

The contacts can be adjusted over the contact position indicator located on the scale. For this purpose, you need to remove the indicator hood, loosen the contact position indicator, set it to the required value and tighten again.

SITRANS F flowmeters

SITRANS F VA

SITRANS FVA250 variable area meter

Analog output with magnetoelectrical transmitter

The magnetoelectrical transmitter is factory-calibrated to the scale intervals.

For HART, the signal output is solely available with 2-wire connection with 4 to 20 mA. The signal output and the limit value can be configured over a HART modem using the configuration program SIMATIC PDM.

The PROFIBUS PA is fitted with an interface for a digital communication circuit in accordance with the FISCO model. The signal output is configured using SIMATIC PDM.

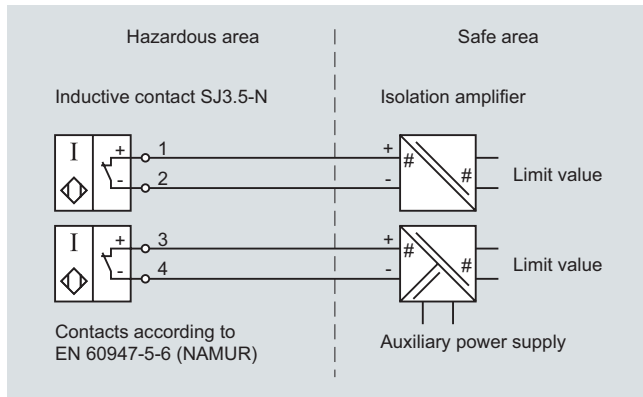

Connection diagram for inductive limit transmitter

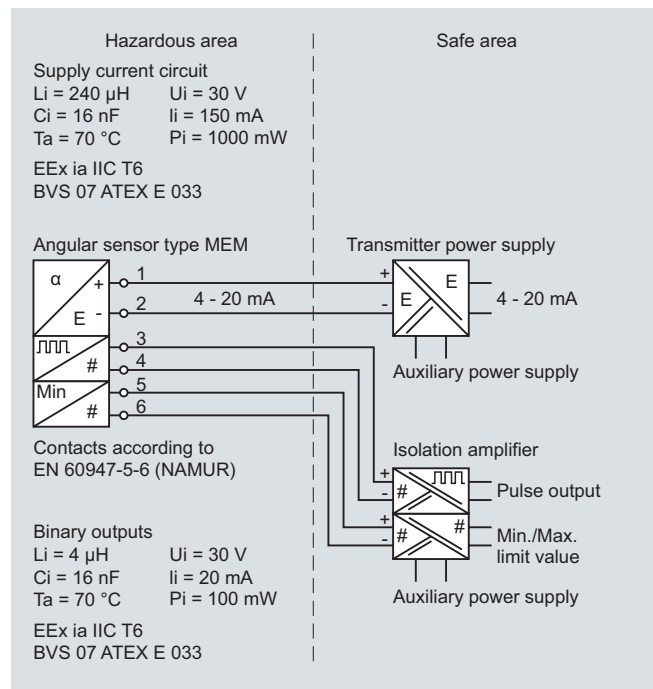

Connection diagram for HART transmitters with 4 to 20 mA output, pulse output and limit contact

Schematics

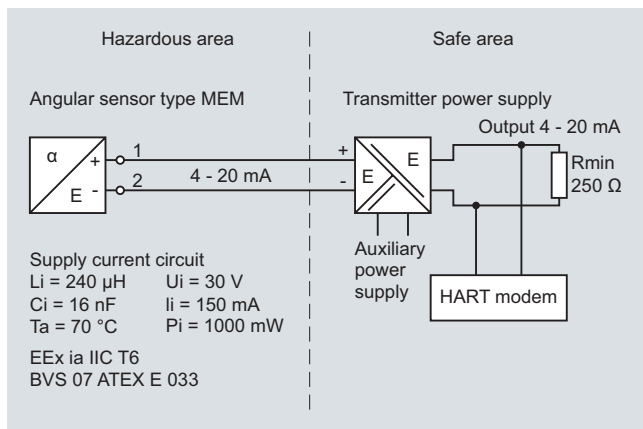

Connection diagram for HART magneto-electrical transmitters

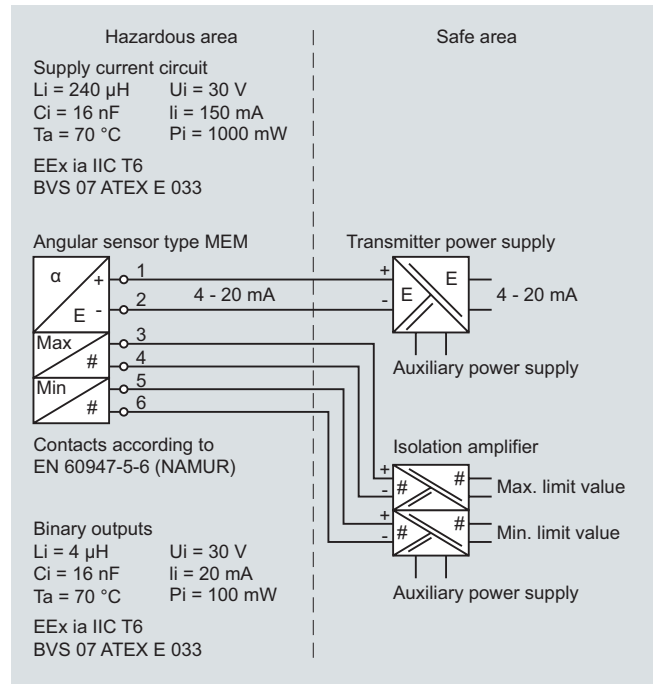

Connection diagram for HART transmitters with 4 to 20 mA output, and 2 limit contacts

4

Measuring ranges for liquids/gases

										Design	CF-S	EF-H	FF-P ¹⁾			
Possible flange connections to EN 1092-1 gray = Type CF-S and Type EF-H X = Type FF-P										Wetted parts materials	Mat. No. 1.4404/316L	Hastelloy C	PTFE			
										Fitting	Mat. No. 1.4404/316L	Mat. No. 1.4571/316Ti	Mat. No. 1.4571/316Ti with PTFE liner			
										Flange	Mat. No. 1.4404/316L	≤ DN 25: Hastelloy > DN 25: Hastelloy/stainless steel	Mat. No. 1.4571/316Ti with PTFE liner			
										Float/flow tube	Mat. No. 1.4404/316L	Hastelloy	PTFE			
										Max. temperature of medium	200 °C (392 °F) optional 350 °C (662 °F)	200 °C (392 °F) optional 350 °C (662 °F)	125 °C (257 °F)			
										Nominal pressure	DN15 ... DN 80 (½ ... 3 inch): PN 40 (580 psi) DN100 (4 inch): PN 16 (232 psi) optional up to 400 bar (5800 psi)	DN15 ... DN 80 (½ ... 3 inch): PN 40 (580 psi) DN100 (4 inch): PN 16 (232 psi) optional up to 400 bar (5800 psi)	PN 16 (232 psi)			
										Measuring ranges	Liquids in l/h with density: 1,0 kg/l, temperature 20 °C (68 °F), viscosity: 1 mPa·s Gas in m³/h with density: 1,293 kg/m³, temperature 20 °C (68 °F), viscosity: 0,0181 mPa·s, p _e = 0 bar (0 psi)					
DN 15 ²⁾	DN 20	DN 25	DN 32	DN 40	DN 50	DN 65	DN 80	DN 100	Pressure loss [mbar] in relation to full-scale value	Order code in MLFB	Liquid l/h	Gas m³/h	Liquid l/h	Gas m³/h	Liquid l/h	Gas m³/h
									40	Z + K1A	5	0.15	–	–	–	–
									40	Z + K1B	10	0.30	–	–	–	–
									40	A	16	0.48	–	–	–	–
									40	B	25	0.75	–	–	–	–
X	X								40	C	40	1.3	–	–	–	–
X	X								40	Z + K1C	50	1.5	50	1.5	50 ¹⁾	1.5 ¹⁾
X	X								40	D	70	2.1	70	2.1	70 ¹⁾	2.1 ¹⁾
X	X								60	E	100	3.0	100	3.0	100 ¹⁾	3.0 ¹⁾
X	X								60	F	160	4.6	160	4.6	160	4.6
X	X								60	G	250	7.0	250	7.0	250	7.0
X	X								70	H	400	11.0	400	11.0	400	11.0
X	X								80	J	600	17.0	600	17.0	600	17.0
	X								60	K	1000	30.0	1000	30.0	1000	30.0
	X								70	L	1600	46.0	1600	46.0	1600	46.0
	X								DN < 40: 100 DN ≥ 40: 50	M	2500	70.0	2500	70.0	2500	70.0
					X				DN < 40: 240 DN ≥ 40: 80	N	4000	110.0	4000	110.0	4000	110.0
						X			DN < 40: 180 DN ≥ 40: 90	P	6000	170.0	6000	170.0	6000	170.0
					X				110	Q	10000	290.0	10000	290.0	10000	290.0
					X		X		DN < 80: 230 DN ≥ 80: 70	R	16000	460.0	16000	460.0	16000	460.0
					X				DN < 80: 230 DN ≥ 80: 70	S	20000	550.0	20000	550.0	–	–
						X			DN < 80: 500 DN ≥ 80: 100	T	25000	700.0	25000	700.0	25000	700.0
						X			DN < 80: 350 DN ≥ 80: 120	U	40000	1100.0	40000	1100.0	40000	1100.0
						X			DN < 80: 350 DN ≥ 80: 120	V	50000	1350.0	50000	1350.0	50000	1350.0
							X		360	W	60000	1700.0	60000	1700.0	–	–
									600	Z + K1D	80000	2400.0	80000	2400.0	–	–
									600	X	100000	3000.0	100000	3000.0	–	–

¹⁾ The measuring range dynamics is always 1:10. For type FF-P, the measuring range dynamics 1:5 for small flow rates.

²⁾ Not available in ANSI ½" for type FF-P; rated size available: ANSI ¾".

SITRANS F flowmeters

SITRANS F VA

SITRANS FVA250 variable area meter

Dimensional drawings

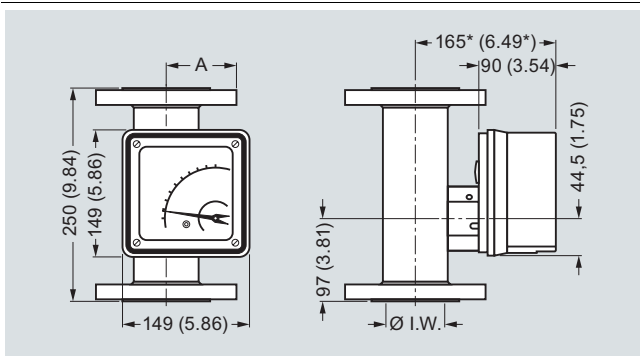

DN	ANSI	I. W.		A		Weight		
		mm	inch	mm	inch	kg	lbs	
15	PN 40 ½"	150 lbs	26	1.02	74	2.91	3,0	6.6
20	PN 40 ¾"	150 lbs	26	1.02	74	2.91	3,0	6.6
25	PN 40 1"	150 lbs	32	1.26	77	3.03	4,2	9.3
32	PN 40 1¼"	150 lbs	32	1.26	77	3.03	5,2	11.5
40	PN40 1½"	150 lbs	46	1.81	88	3.46	6,0	13.2
50	PN 40 2"	150 lbs	70	2.76	97	3.82	7,5	16.5
65	PN 16 2½"	150 lbs	70	2.76	97	3.82	8,5	18.7
80	PN 16 3"	150 lbs	102	4.02	113	4.45	13	28.7
100	PN 16 4"	150 lbs	125	4.92	126	4.96	18	39.7

* + 100 mm (3.94 inch) with pulled-out display unit

SITRANS FVA250, enclosure of display unit made of aluminum, dimensions in mm (inch)

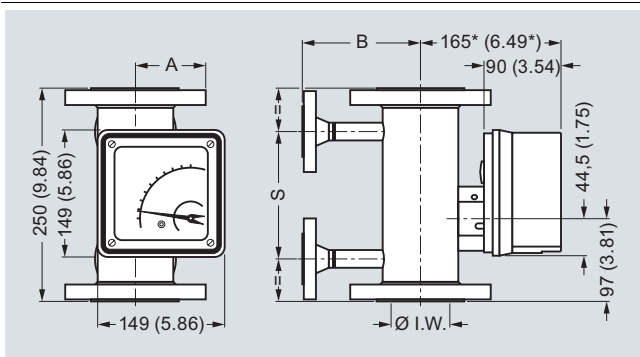

DN	B (flange)		B (Ermeto)		S		Weight		
	mm	inch	mm	inch	mm	inch	kg	lbs	
15	½"	110	4.33	53	2.09	150	5.91	3,0	6.6
20	¾"	110	4.33	53	2.09	150	5.91	3,0	6.6
25	1"	110	4.33	58,5	2.3	150	5.91	4,2	9.3
32	1¼"	110	4.33	58,5	2.3	150	5.91	5,2	11.5
40	1½"	130	5.12	63	2.48	150	5.91	6,0	13.2
50	2"	140	5.51	77,5	3.05	150	5.91	7,5	16.5
65	2½"	140	5.51	77,5	3.05	150	5.91	8,5	18.7
80	3"	160	6.3	93,5	3.68	150	5.91	13	28.7
100	4"	175	6.89	110	4.33	120	4.72	18	39.7

* + 100 mm (3.94 inch) with pulled-out display unit

SITRANS FVA250, enclosure of display unit made of aluminum with heating connection, dimensions in mm (inch)

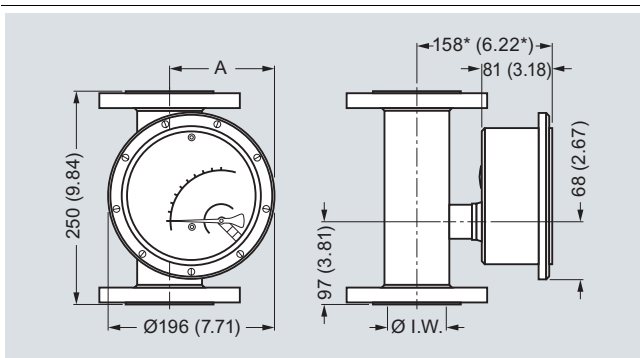

DN	ANSI	I. W.		A		Weight		
		mm	inch	mm	inch	kg	lbs	
15	PN 40 ½"	150 lbs	26	1.02	103	4.06	3,0	6.6
20	PN 40 ¾"	150 lbs	26	1.02	103	4.06	3,0	6.6
25	PN 40 1"	150 lbs	32	1.26	105	4.13	4,2	9.3
32	PN 40 1¼"	150 lbs	32	1.26	105	4.13	5,2	11.5
40	PN 40 1½"	150 lbs	46	1.81	115	4.53	6,0	13.2
50	PN 40 2"	150 lbs	70	2.76	129	5.08	7,5	16.5
65	PN 16 2½"	150 lbs	70	2.76	129	5.08	8,5	18.7
80	PN 16 3"	150 lbs	102	4.02	145	5.71	13	28.7
100	PN 16 4"	150 lbs	125	4.92	158	6.22	18	39.7

* + 100 mm (3.94 inch) with pulled-out display unit

SITRANS FVA250, enclosure of display unit made of stainless steel, dimensions in mm (inch)

Selection and Ordering data	Order No.	Order Code
SITRANS FVA250 variable area meter, made completely of metal		
• for the measurement of liquids	7ME5822 - 0 -	
• for the measurement of gases	7ME5823 - 0 -	
Design		
<u>Type: CF-S (standard)</u> Fitting: Stainless steel 1.4404/316L, Flange: Stainless steel 1.4404/316L float: Stainless steel 1.4404/316L	2	
<u>Type: EF-H</u> Fitting: Stainless steel 1.4404/316L, Flange: 1.4404/316L with Hastelloy liner float: Hastelloy	4	
<u>Type: FF-P</u> Fitting: Stainless steel 1.4404/316L, Flange: 1.4404/316L with PTFE liner float: PTFE	5	
Nominal diameter/flange connection		
<u>Flange to DIN 2501</u>		
DN 15, PN 40	A	
DN 20, PN 40	F	
DN 25, PN 40	B	
DN 32, PN 40	G	
DN 40, PN 40	H	
DN 50, PN 40	C	
DN 65, PN 16	J	
DN 65, PN 40	Z	J 1 A
DN 80, PN 40	D	
DN 100, PN 16	E	
DN 100, PN 40	Z	J 1 B
<u>Flanges to ASME</u>		
½" ANSI 150 RF B16.5 (not for DN15 with type FF-P)	K	
½" ANSI 300 RF B16.5 (not for DN15 with type FF-P)	Z	J 2 A
¾" ANSI 150 RF B16.5	L	
¾" ANSI 300 RF B16.5	Z	J 2 B
1" ANSI 150 RF B16.5	M	
1" ANSI 300 RF B16.5	Z	J 2 C
1¼" ANSI 150 RF B16.5	N	
1¼" ANSI 300 RF B16.5	Z	J 2 D
1½" ANSI 150 RF B16.5	P	
1½" ANSI 300 RF B16.5	Z	J 2 E
2" ANSI 150 RF B16.5	Q	
2" ANSI 300 RF B16.5	Z	J 2 F
2½" ANSI 150 RF B16.5	R	
2½" ANSI 300 RF B16.5	Z	J 2 G
3" ANSI 150 RF B16.5	S	
3" ANSI 300 RF B16.5	Z	J 2 H
4" ANSI 150 RF B16.5	T	
4" ANSI 300 RF B16.5	Z	J 2 J

SITRANS F flowmeters

SITRANS F VA

SITRANS FVA250 variable area meter

Selection and Ordering data

Order No.

Order Code

SITRANS FVA250 variable area meter, made completely of metal

- for the measurement of liquids
- for the measurement of gases

7ME5 822 - 0 - - - - -
7ME5 823 - 0 - - - - -

Flow tube

Measuring range for liquids l/h	Measuring range for gases m³/h	Nominal diameters		
		FF-P	EF-H	CF-S
0.5 ... 5	0.015 ... 0.15	-	-	DN 15 ... 25
1 ... 10	0.03 ... 0.3	-	-	DN 15 ... 25
1.6 ... 16	0.045 ... 0.48	-	-	DN 15 ... 25
2.5 ... 25	0.075 ... 0.75	-	-	DN 15 ... 25
4 ... 40	0.13 ... 1.3	-	-	DN 15 ... 25
5 ... 50	0.15 ... 1.5	DN 15 ... 25	DN 15 ... 25	DN 15 ... 25
7 ... 70	0.2 ... 2.1	DN 15 ... 25	DN 15 ... 25	DN 15 ... 25
10 ... 100	0.3 ... 3.0	DN 15 ... 25	DN 15 ... 25	DN 15 ... 25
16 ... 160	0.5 ... 4.6	DN 15 ... 25	DN 15 ... 25	DN 15 ... 25
25 ... 250	0.7 ... 7.0	DN 15 ... 25	DN 15 ... 25	DN 15 ... 25
40 ... 400	1.0 ... 11	DN 15 ... 25	DN 15 ... 25	DN 15 ... 25
60 ... 600	1.7 ... 17	DN 15 ... 25	DN 15 ... 25	DN 15 ... 40
100 ... 1 000	3 ... 30	DN 25	DN 15 ... 25	DN 15 ... 40
160 ... 1 600	4 ... 46	DN 25	DN 15 ... 25	DN 15 ... 40
250 ... 2 500	7 ... 70	DN 25	DN 15 ... 25	DN 15 ... 40
400 ... 4 000	11 ... 110	DN 50	DN 25 ... 65	DN 25 ... 65
600 ... 6 000	17 ... 170	DN 50	DN 40 ... 65	DN 40 ... 65
1 000 ... 10 000	29 ... 290	DN 50	DN 50 ... 65	DN 50 ... 65
1 600 ... 16 000	46 ... 460	DN 50 ... 80	DN 50 ... 80	DN 50 ... 80
2 000 ... 20 000	55 ... 550	-	DN 50 ... 80	DN 50 ... 80
2 500 ... 25 000	70 ... 700	DN 80	DN 50 ... 80	DN 50 ... 80
4 000 ... 40 000	110 ... 1 100	DN 100	DN 80 ... 100	DN 80 ... 100
5 000 ... 50 000	135 ... 1 350	DN 100	DN 80 ... 100	DN 80 ... 100
6 000 ... 60 000	170 ... 1 700	-	DN 100	DN 100
8 000 ... 80 000	240 ... 2 400	-	DN 100	DN 100
10 000 ... 100 000	300 ... 3 000	-	DN 100	DN 100

Z K 1 A
Z K 1 B
A
B
C
Z K 1 C
D
E
F
G
H
J
K
L
M
N
P
Q
R
S
T
U
V
W
Z X K 1 D

Temperature shield/degree of protection

Standard up to 150 °C for electric output/200 °C for local display
Standard, with displaced display
Stainless steel IP66 for process temperature 150 °C
Stainless steel IP66 preferred

0
2
5
6

Heating/cooling sheath

Without (standard)
H/C with flange connection
H/C without flange connection

0
2
3

Display

With local display
With local display and an inductive contact, SJ 3.5N (1 NC for downward violation of a limit value)
With local display and two inductive contacts, SJ 3.5N
With HART protocol, 4 ... 20 mA, EEx ia
With HART protocol, 4 ... 20 mA, EEx ia with two inductive contacts, SJ 3.5N (1 NO contact for downward violation of a limit value, 1 NO contact for upward violation of a limit value)
With HART protocol, 4 ... 20 mA, EEx ia with one inductive contact, SJ 3.5N and a pulse output (1 NC contact for downward violation of a limit value)
Electric transmitter with PROFIBUS PA, EEx ia

AA
CJ
CL
FA
GL
HJ
PA

Calibration

Standard calibration
• Without calibration certificate
• With calibration certificate

0
1

4

Selection and Ordering data

Order Code

Further designs for measurement of liquids and gases

Add "-Z" to Order No. and specify Order Code.

Rating plate in English**B11****Factory certificate 2.2****C11****Acceptance test B**

to DIN 50 049, Section 3.1 and EN 10 204

C12**Measured medium**

specify in plain text (always required) Medium, measuring range, dimension, density, density dimension, viscosity, viscosity dimension, operating temperature, operating pressure

Y01**Silicone-free version****Y04****Stainless steel tag plate****Y17****Specify special version** in plain text**Y99****Note:****For all possible combinations of nominal diameters and flow tubes, see the table on page 4/343****Selection and Ordering data**

Order Code

Further designs for measurement of liquids

Add "-Z" to Order No. and specify Order Code

Limit stop and damping

DN 15 DN 20 DN 25 DN 32 DN 40 DN 50 DN 65 DN 80 DN 100

Type CF-S with liquid damping**D01 D02 D03 D04 D05 D06 D07 D08 D09****Type EF-H** with liquid damping**E01 E02 E03 E04 E05 E06 E07 E08 E09****Type FF-P** with liquid damping**P01 – P03 – – P06 – P08 P09**

Note: The overall length for the FF-P version is 5 mm (0.2") longer.

Selection and Ordering data

Order Code

Further designs for measurement of gases

Add "-Z" to Order No. and specify Order Code.

Limit stop and damping

DN 15 DN 20 DN 25 DN 32 DN 40 DN 50 DN 65 DN 80 DN 100

Type CF-S with gas damping**D11 D12 D13 D14 D15 D16 D17 D18 D19****Type EF-H** with gas damping**E11 E12 E13 E14 E15 E16 E17 E18 E19****Type FF-P** with gas damping**P11 – P13 – – P16 – P18 P19**

Note: The overall length for the FF-P version is 5 mm (0.2") longer.